

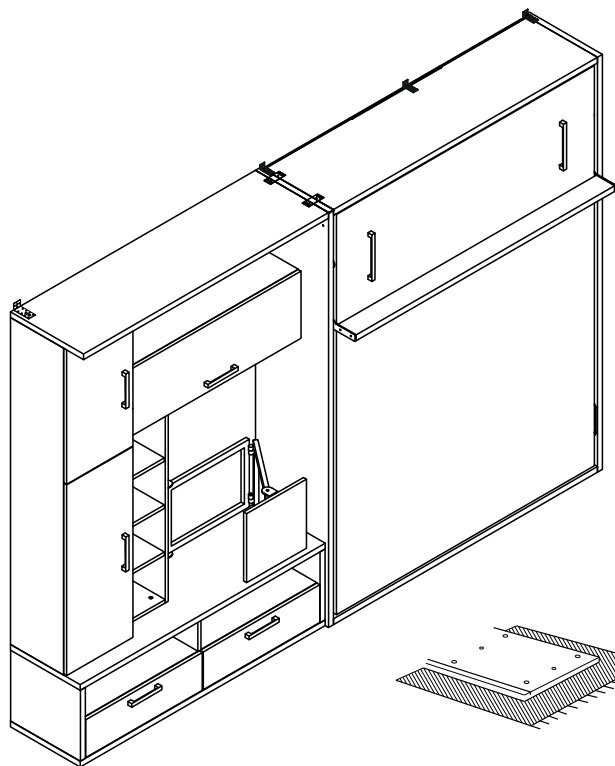

# MULTIMO

## 161- SALOON NEW



**100**min.



Technical Service



**220**min.



End User

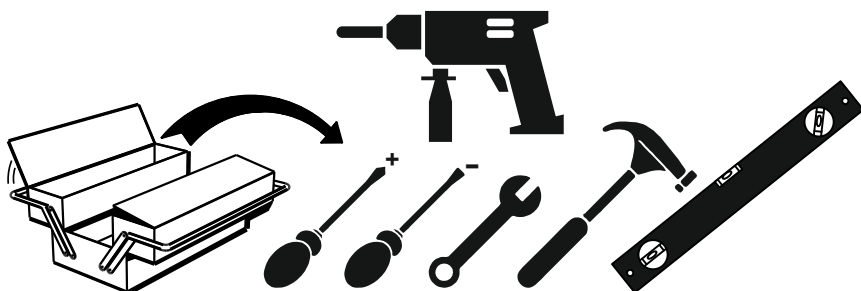
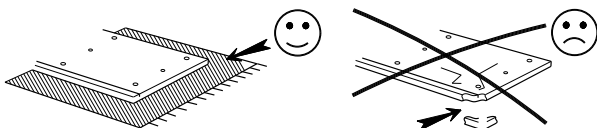

VIDEO

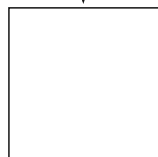









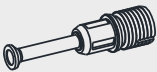

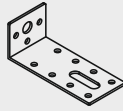
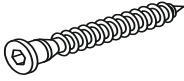

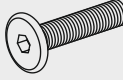

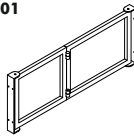



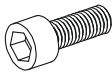

link

Assembly Instructions

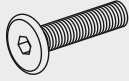
Track Title	Piece	(inch)			(mm)			
		Thickness	Length	Width	Piece	Thick	Height	Most
<b>A</b>	1	57,32	16,54	1,18	1	1456	420	30
<b>B (R-L)</b>	2	81,89	17,32	0,71	2	2080	440	18
<b>C</b>	1	57,32	17,32	1,18	1	1456	440	30
<b>D</b>	2	57,32	5,91	0,71	2	1456	150	18
<b>E</b>	1	57,32	4,33	1,18	1	1456	110	30
<b>F</b>	1	58,11	17,32	0,71	1	1476	440	18
<b>G (R-L)</b>	2	63,78	12,60	0,71	2	1620	320	18
<b>H</b>	2	14,33	12,60	0,71	2	364	320	18
<b>I</b>	1	14,33	11,81	0,71	1	364	300	18
<b>J</b>	3	14,33	11,02	0,71	3	364	280	18
<b>K</b>	2	12,36	10,24	0,71	2	314	260	18
<b>L</b>	2	42,28	10,24	0,71	2	1074	260	18
<b>M</b>	1	58,19	16,54	16,93	1	1478	420	430
<b>N (R-L)</b>	2	39,37	9,84	0,71	2	1000	250	18
<b>O</b>	2	10,39	9,84	0,71	2	264	250	18
<b>P</b>	2	10,39	8,86	0,71	2	264	225	18
<b>R</b>	1	24,25	15,67	0,71	1	616	398	18
<b>S</b>	1	39,17	15,67	0,71	1	995	398	18
<b>T</b>	1	42,05	14,17	0,71	1	1068	360	18
<b>U</b>	1	78,54	56,46	0,71	1	1995	1434	18
<b>Y</b>	1	10,39	8,86	0,71	1	264	225	18
<b>Z</b>	1	9,84	5,71	0,71	1	250	145	18
<b>X-1</b>	3	81,06	7,48	0,31	3	2059	190	8
<b>X-2</b>	1	63,03	15,00	0,31	1	1601	381	8
<b>X-3</b>	1	41,54	13,03	0,31	1	1055	331	8
<b>X-4</b>	1	38,58	11,02	0,31	1	980	280	8
<b>X-5</b>	1	12,05	43,70	0,31	1	360	360	18

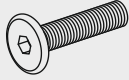
# Accessories List

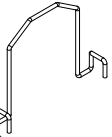
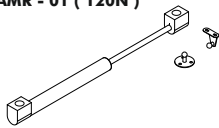
<p><b>MXN 02</b></p>  <p><b>46 / piece</b></p> <p><b>TFC - 01 (8x70) mm</b></p>	<p><b>MNG - 01</b></p>  <p><b>46 / piece</b></p> <p><b>DSE - 01 (40x90x32) mm</b></p>  <p><b>4 / piece</b></p> <p><b>VDA - 01 ( 6,5x50 ) mm</b></p>  <p><b>4 / piece</b></p> <p><b>AVT - 01</b></p>  <p><b>7 / piece</b></p> <p><b>TSY - 01</b></p>  <p><b>2 / piece</b></p> <p><b>CT - 03 ( 6x50 ) mm</b></p>  <p><b>10 / piece</b></p> <p><b>KP - 01 ( 128 ) mm</b></p>  <p><b>5 / piece</b></p> <p><b>SC - 76</b></p>  <p><b>2 / piece</b></p> <p><b>TVM - 01</b></p>  <p><b>1 / piece</b></p>	<p><b>KVL 01</b></p>  <p><b>48 / piece</b></p> <p><b>VTB - 01 (4,8x16) mm</b></p>  <p><b>24 / piece</b></p> <p><b>TAP - 02</b></p>  <p><b>4 / piece</b></p> <p><b>IM - 01 (6x30) mm</b></p>  <p><b>4 / piece</b></p> <p><b>VD - 03 ( 3,5x18 ) mm</b></p>  <p><b>30 / piece</b></p> <p><b>VKP - 01 (22) mm</b></p>  <p><b>10 / piece</b></p> <p><b>H 01</b></p>  <p><b>2 / piece</b></p>	<p><b>TAP - 01</b></p>  <p><b>46 / piece</b></p> <p><b>PL - 02 (8x22x1) mm</b></p>  <p><b>4 / piece</b></p> <p><b>OT-054</b></p>  <p><b>2 / piece</b></p> <p><b>CT - 01 ( 6x40 ) mm</b></p>  <p><b>2 / piece</b></p> <p><b>PM - 01</b></p>  <p><b>20 / piece</b></p> <p><b>CT - 05 ( 6x35 ) mm</b></p>  <p><b>4 / piece</b></p> <p><b>VKP - 03 (40) mm</b></p>  <p><b>4 / piece</b></p> <p><b>TTC 01</b></p>  <p><b>4 / piece</b></p>
<p><b>AMR - 01 ( 120N )</b></p>  <p><b>1 / piece</b></p>	<p><b>1200 N</b></p>		

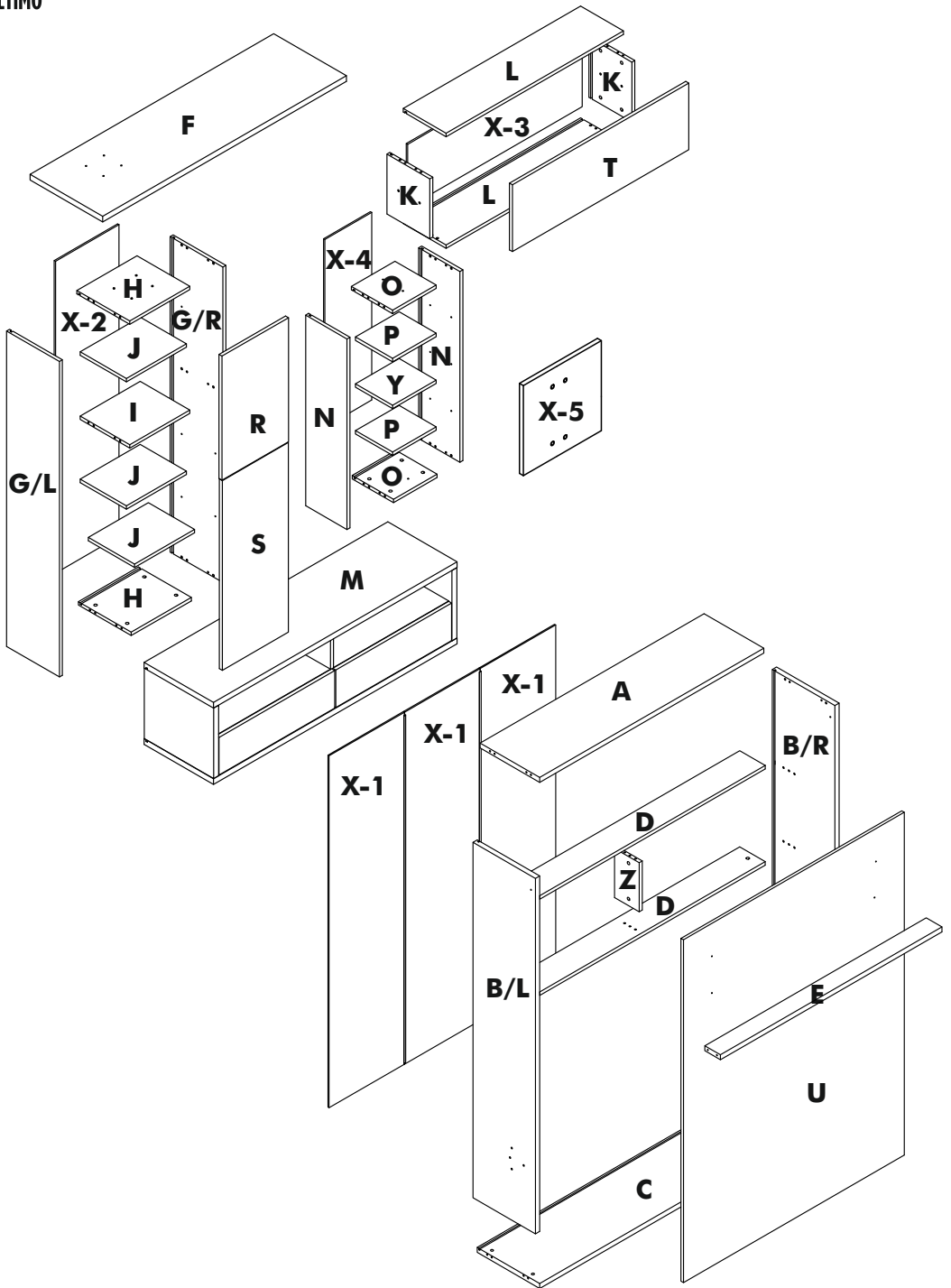

**STEP 1**



**MNX - 02**

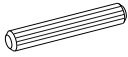

**KVL 01**

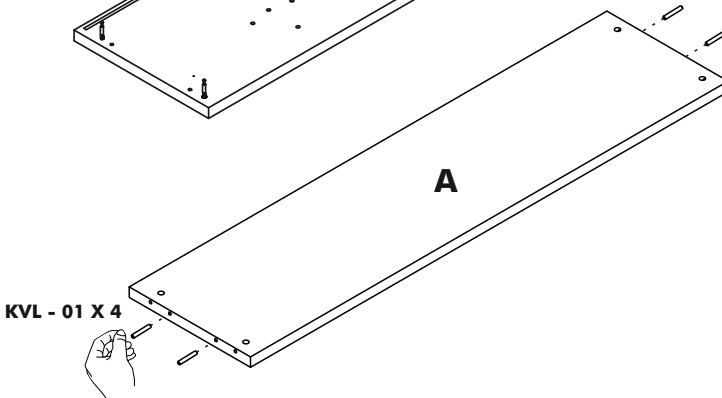
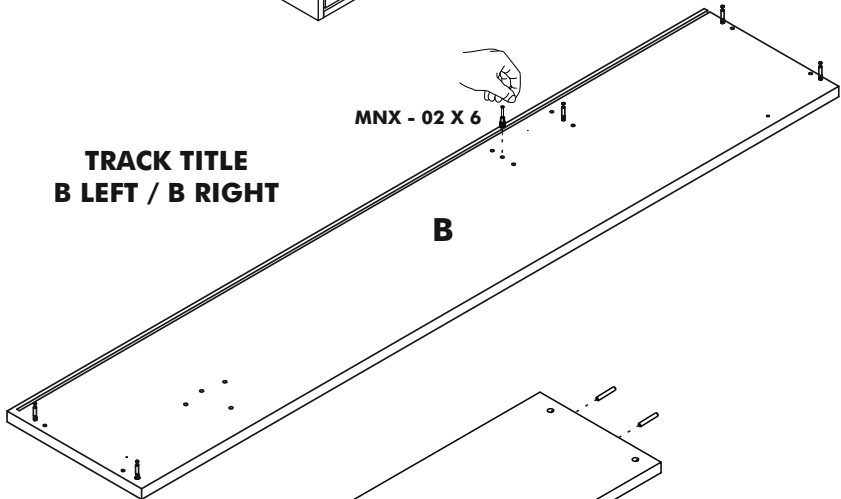
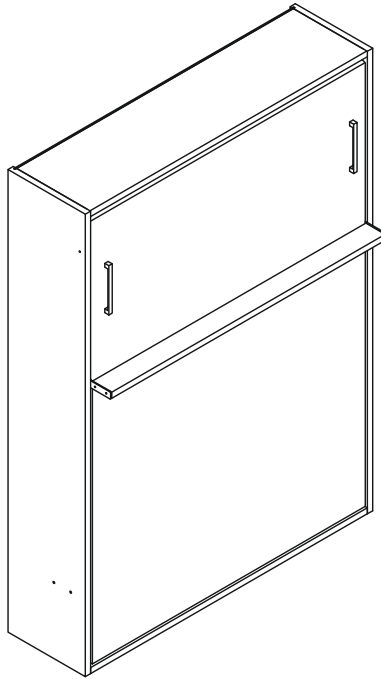

**VIDEO**

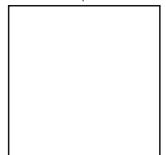

link

**STEP 2**

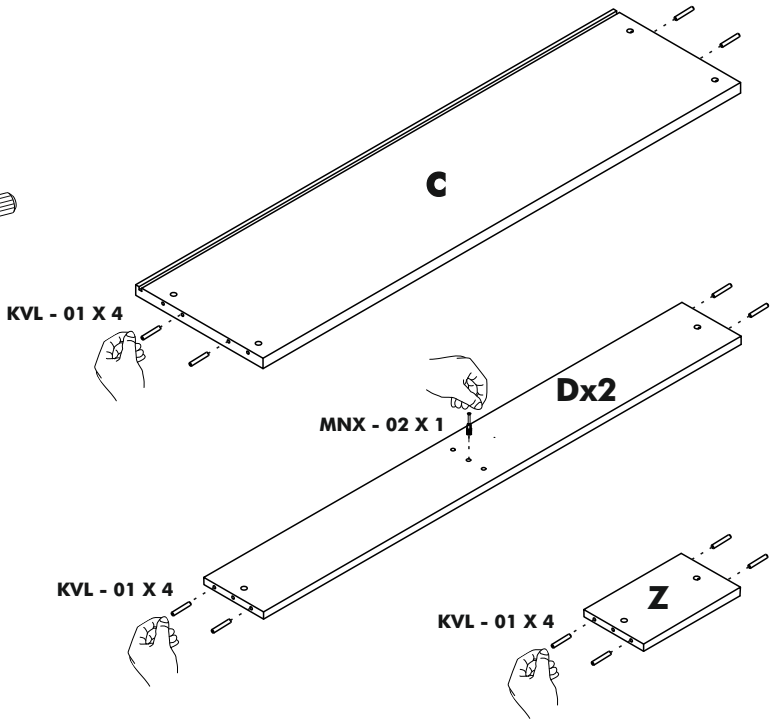

**STEP 3**

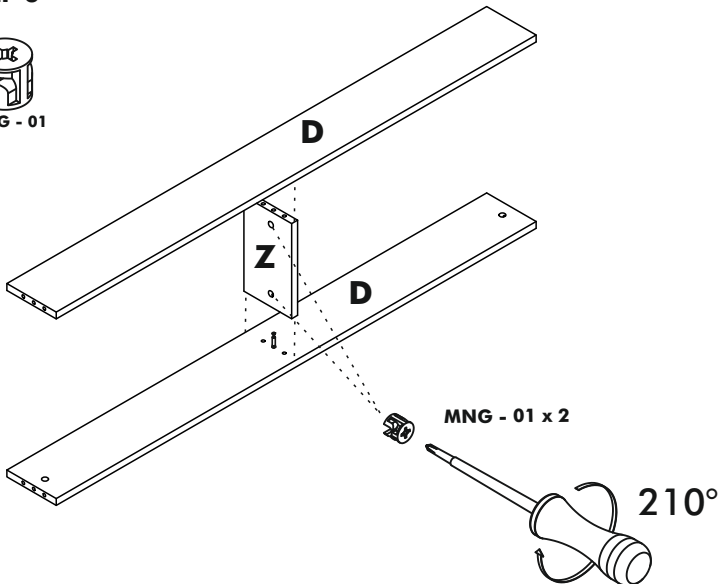

VIDEO

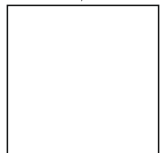

link

**STEP 4**

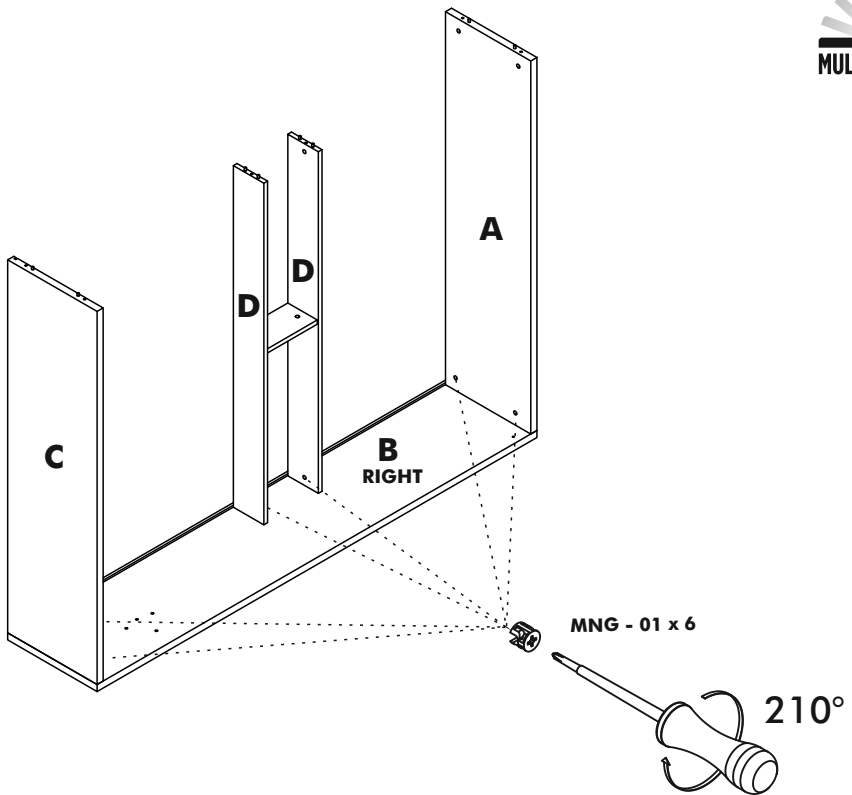

**STEP 5**

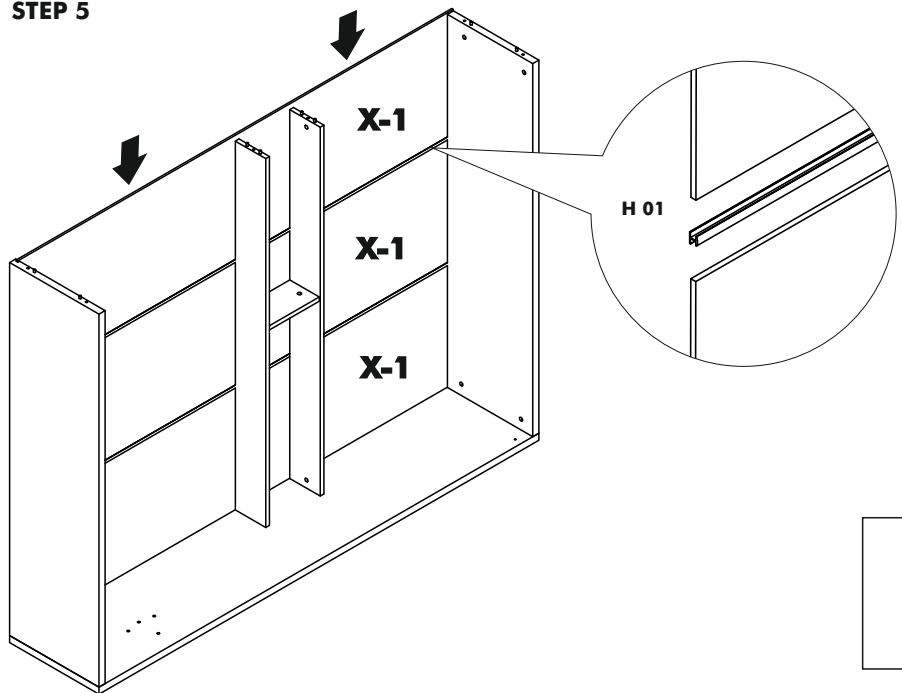

**STEP 6**

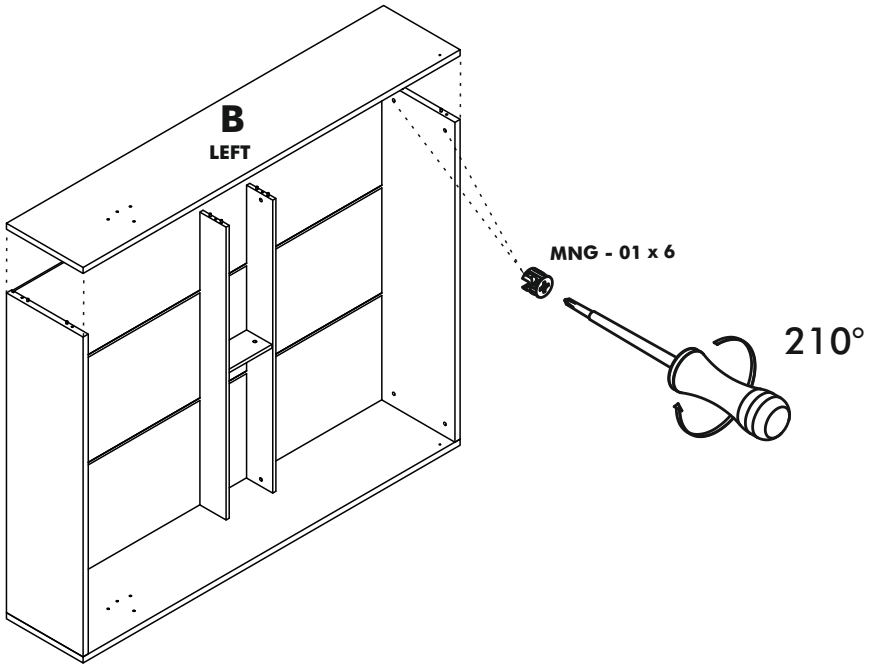

**STEP 7**

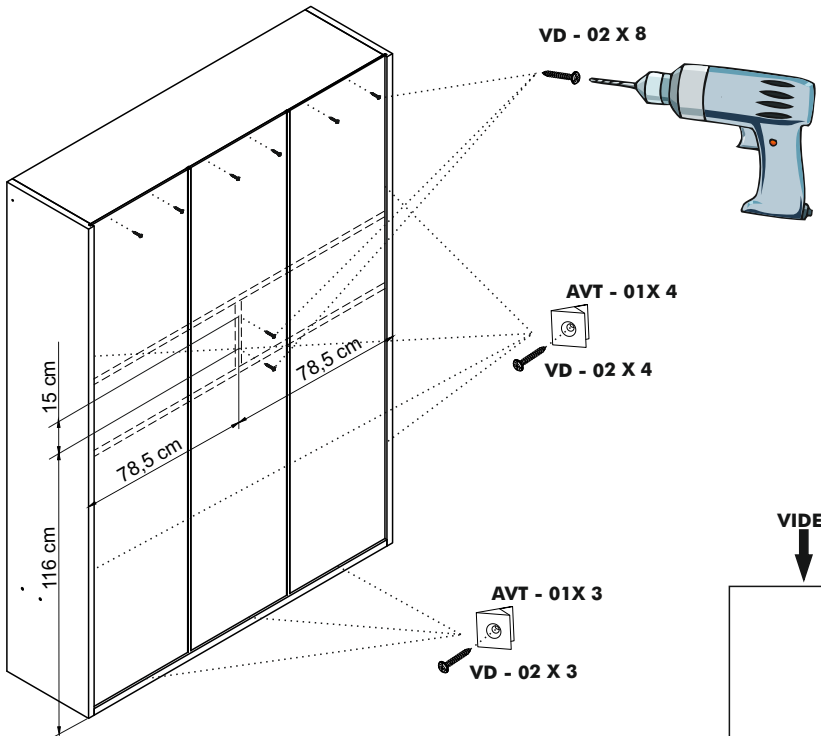



# STEP 8

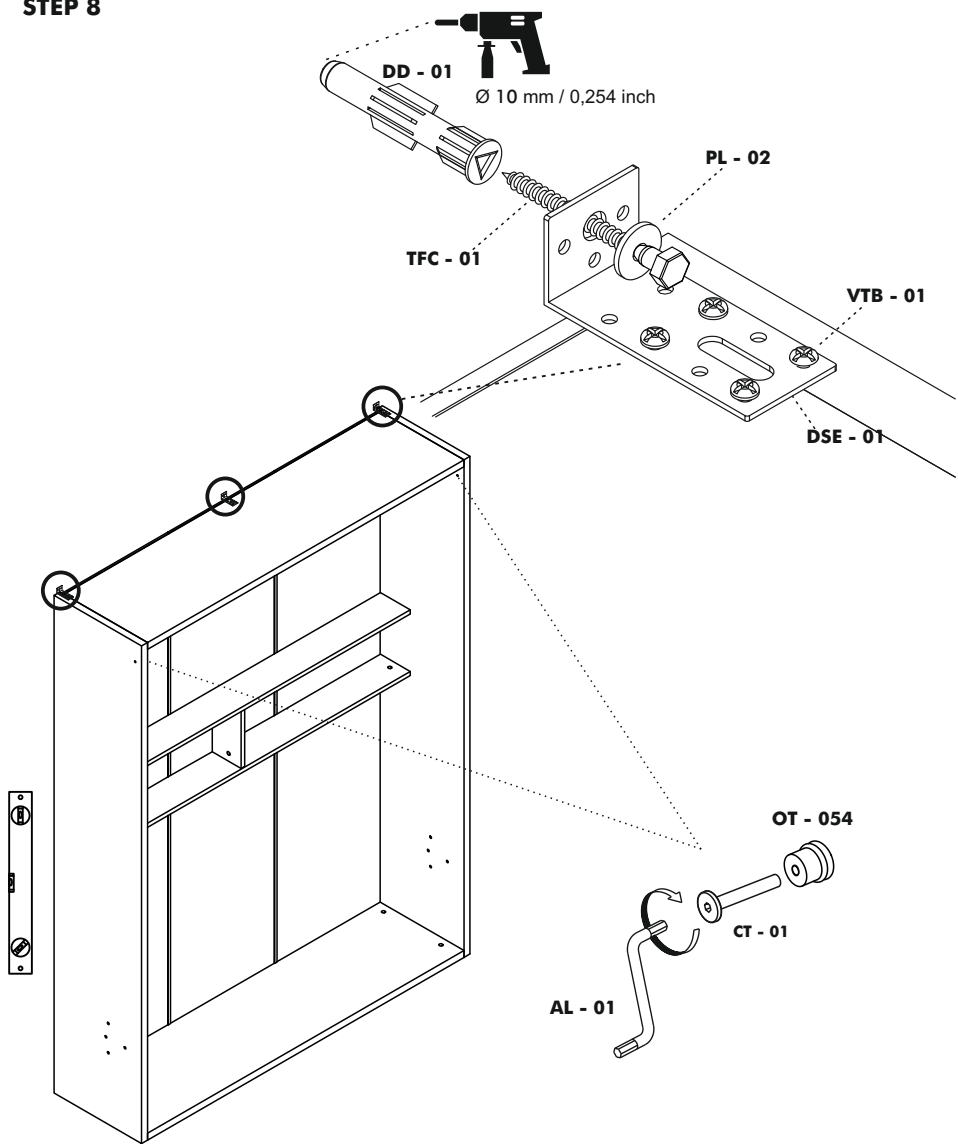

**VIDEO**

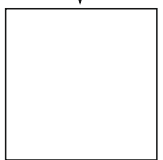

link

STEP 9

**CAUTION**  
**DO NOT UNLOCK**  
**BEFORE INSTALL**

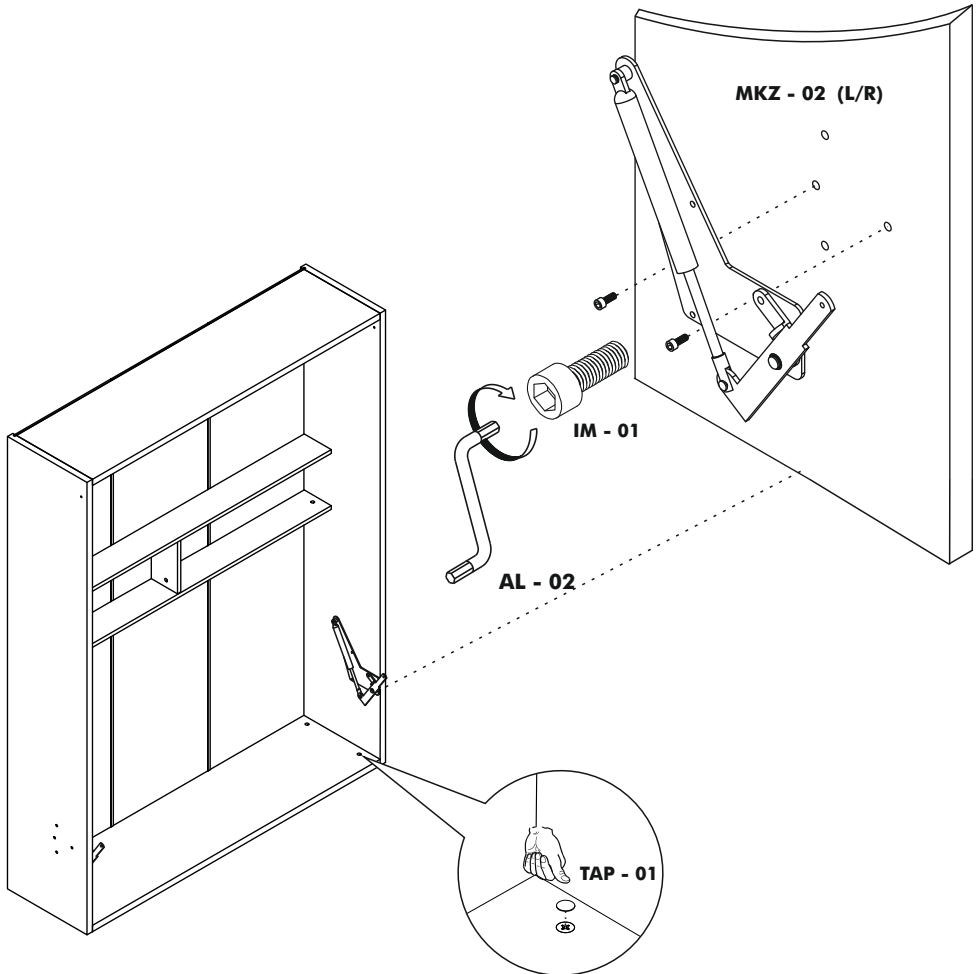

**VIDEO**

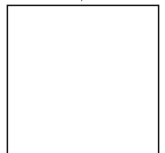

link

**STEP 10**

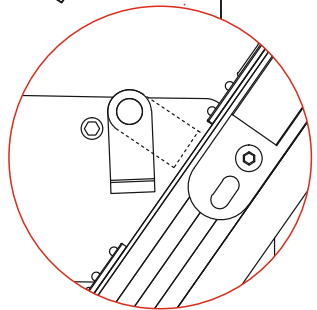
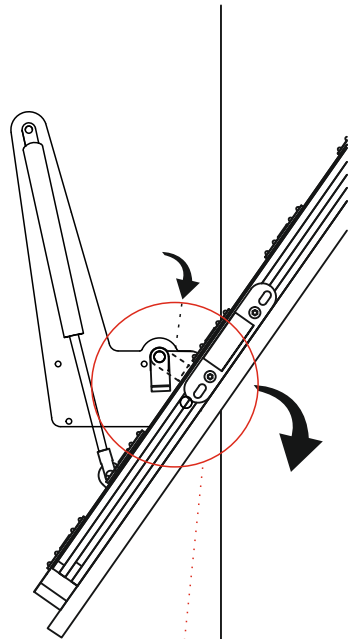
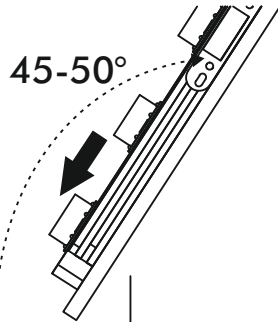
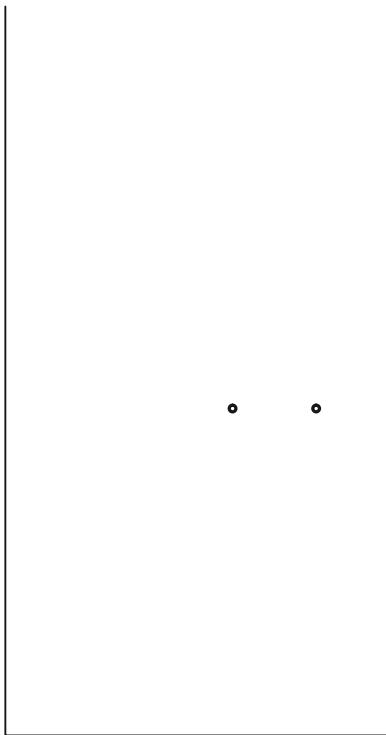

**LET THE STOPPER LOCK MOVE DOWN !!!**

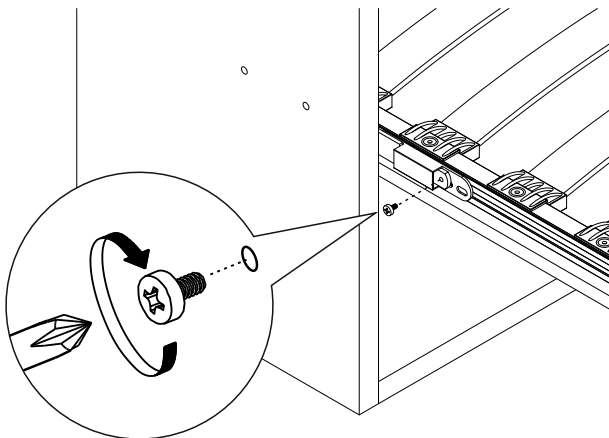

**VIDEO**

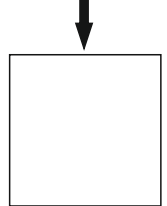

link

STEP 11

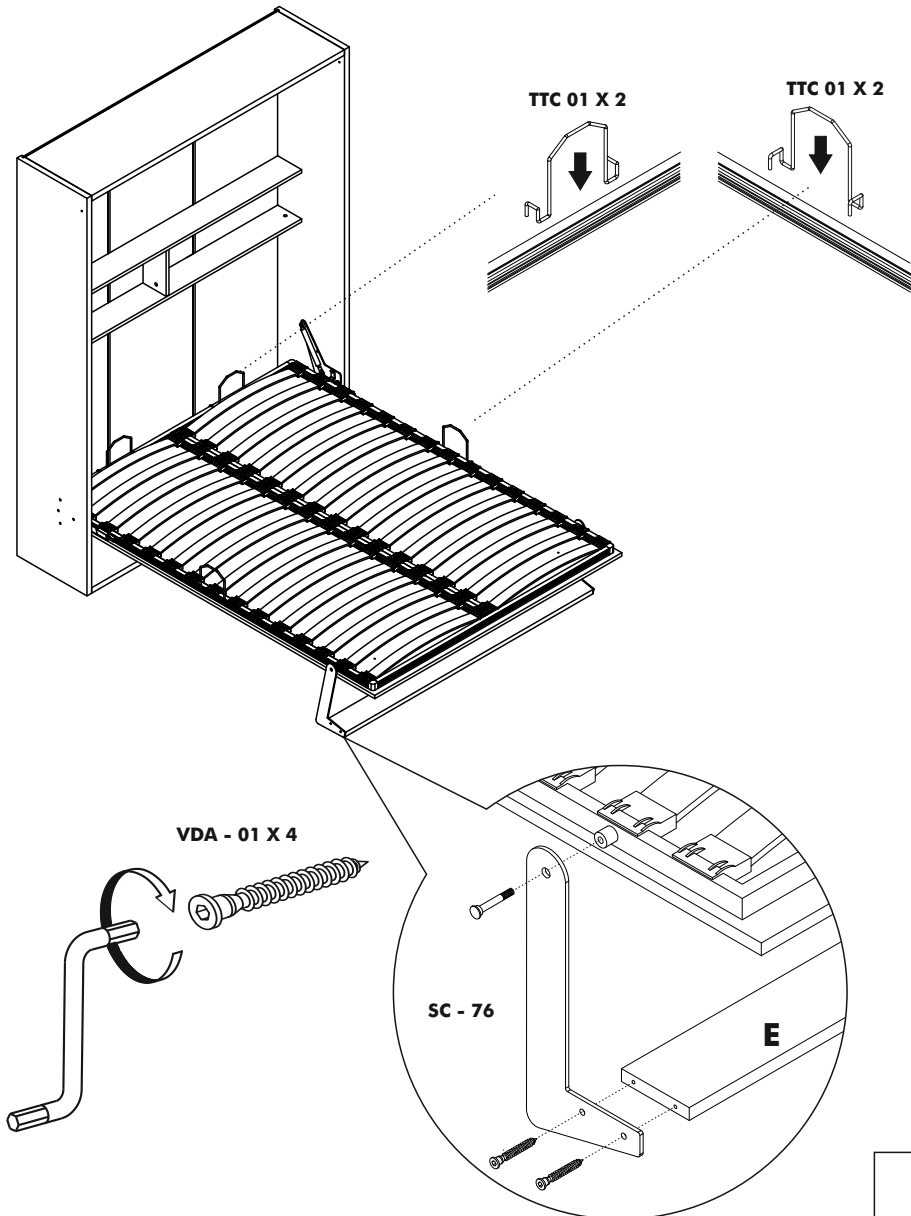

VIDEO

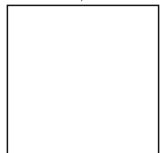

link

**STEP 12**

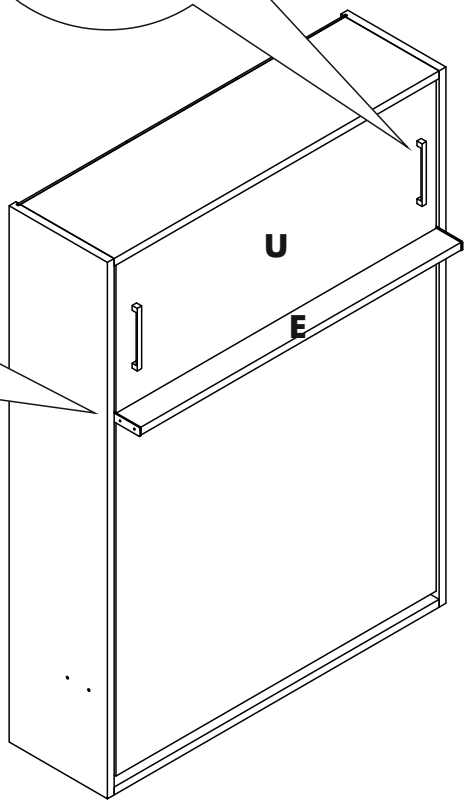
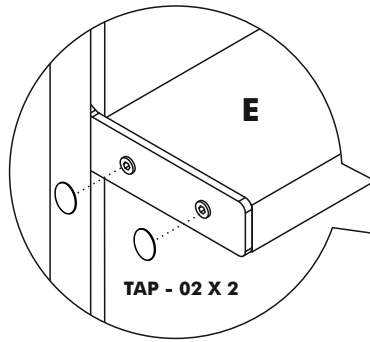
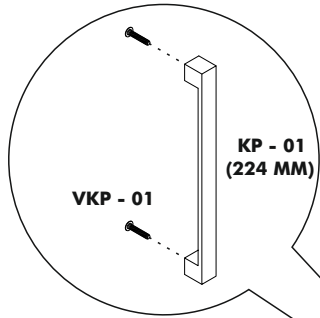

**VIDEO**



link

**STEP 13**

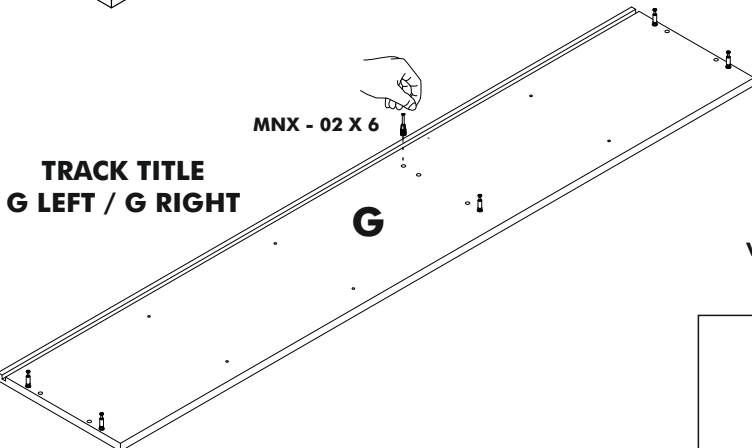
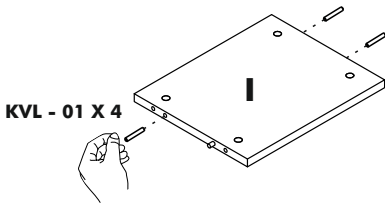
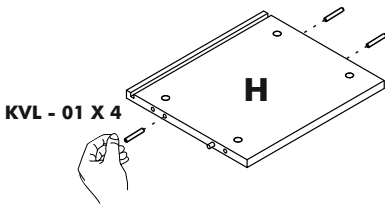
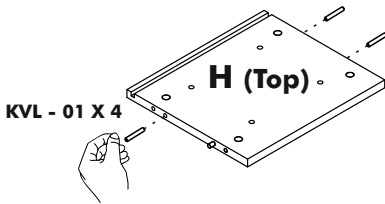
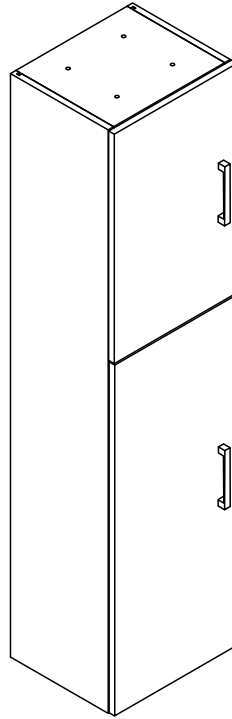
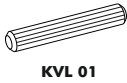

**VIDEO**

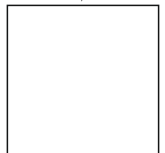

link

**STEP 14**

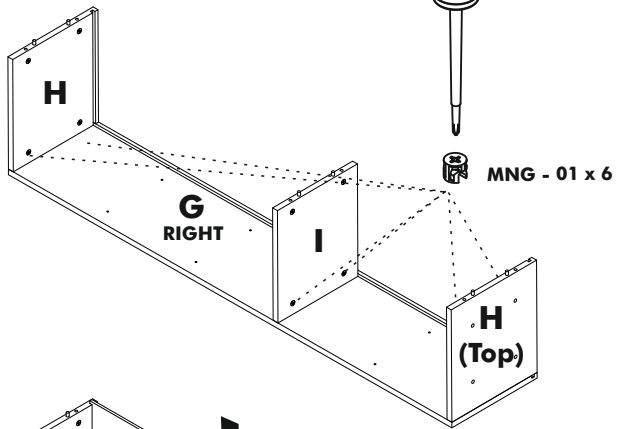
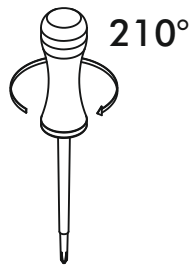

**STEP 15**

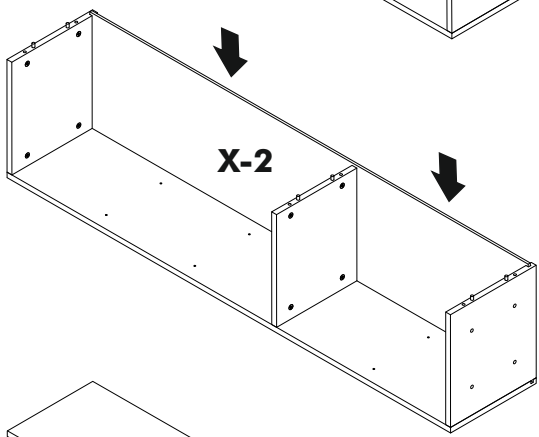

**STEP 16**

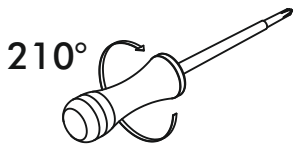
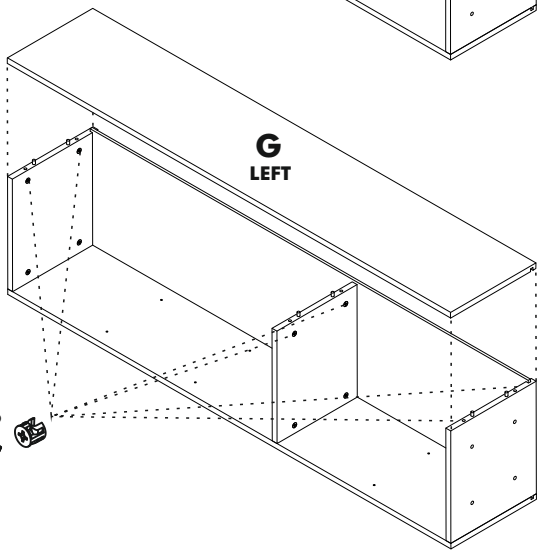

**VIDEO**

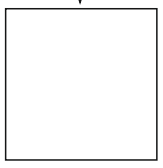

link

**STEP 17**

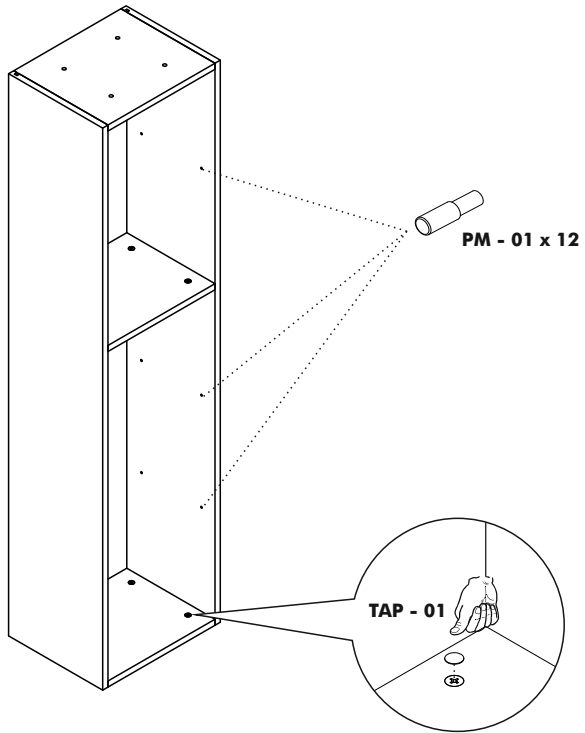

**STEP 18**

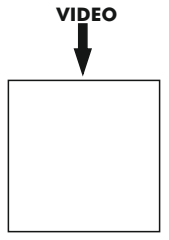
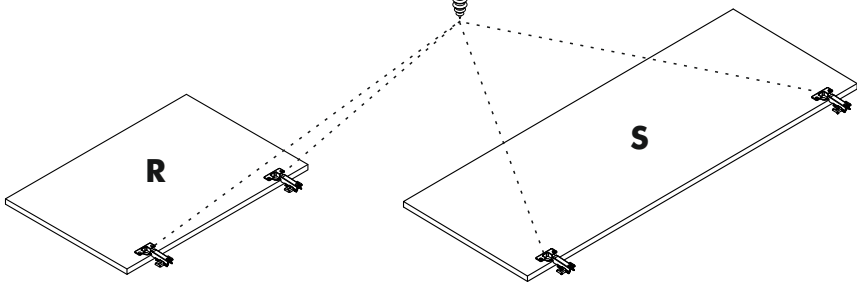
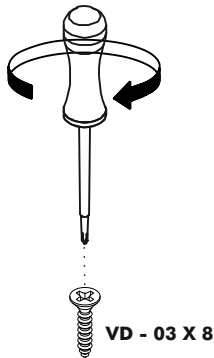
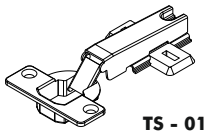



**STEP 19**

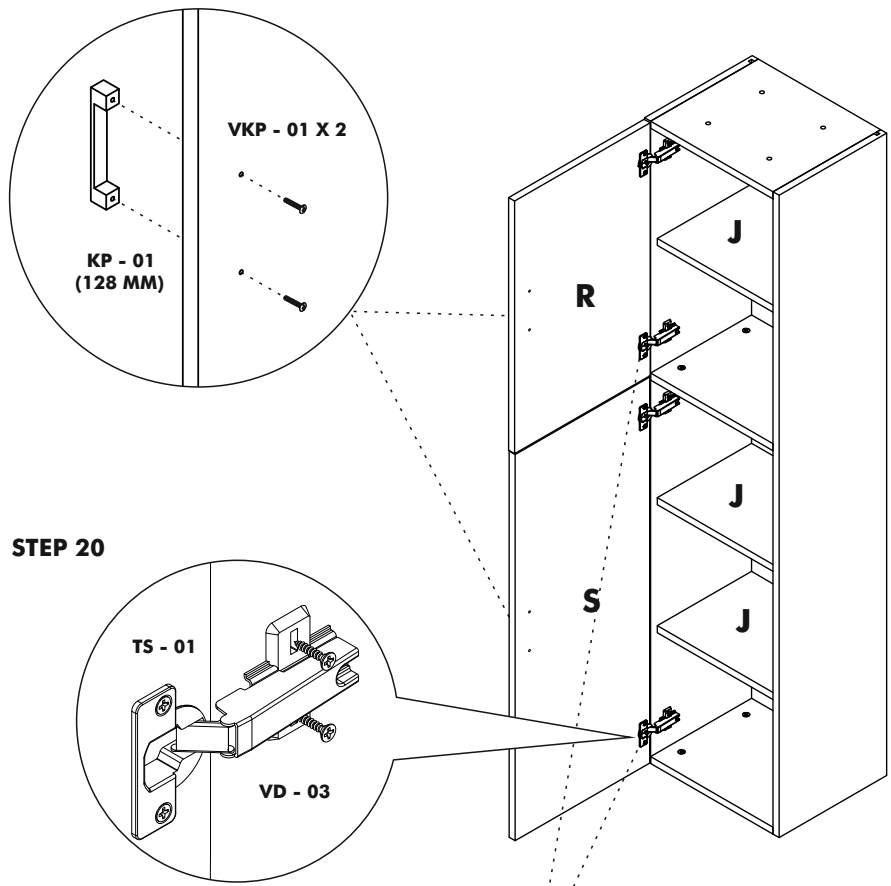

**STEP 20**

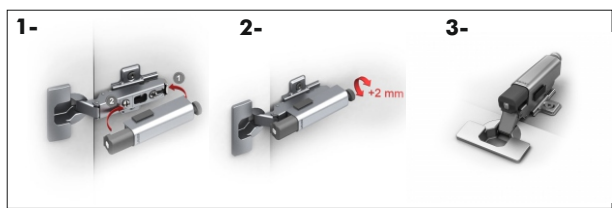
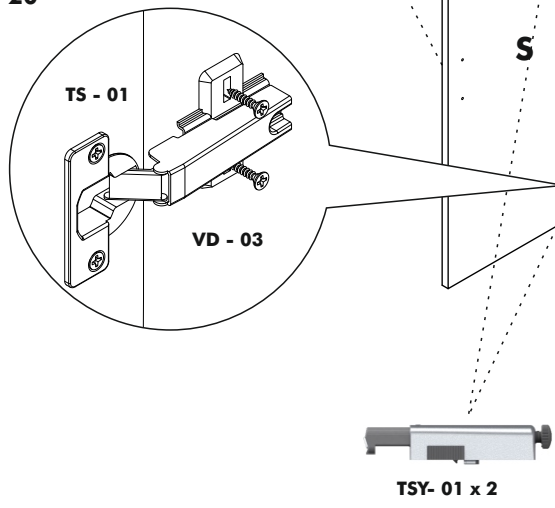

**VIDEO**

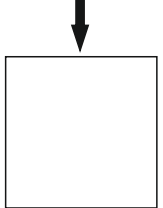

link

### STEP 21



MNX - 02

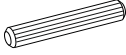

KVL 01

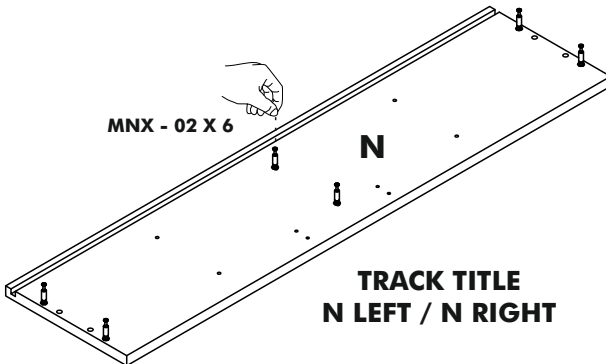
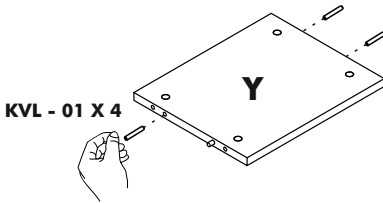
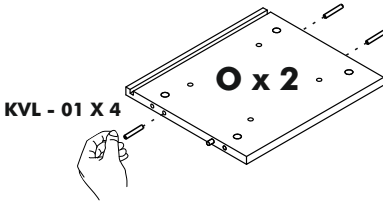
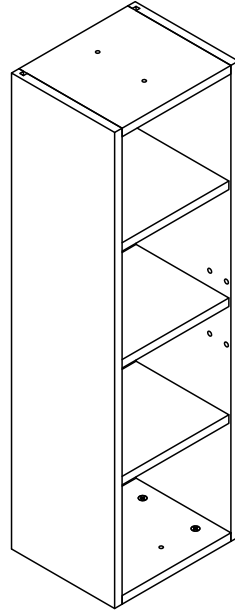

VIDEO

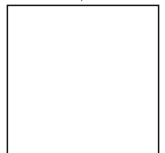

link

**STEP 22**

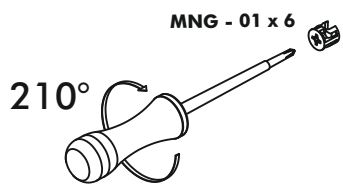
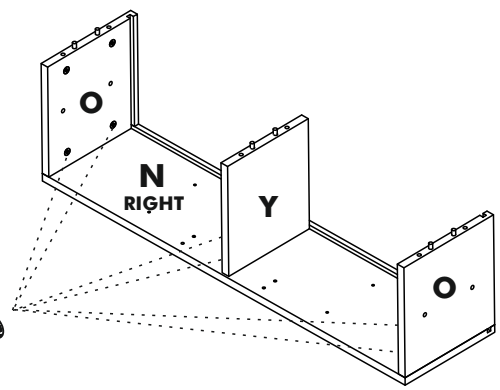

**STEP 23**

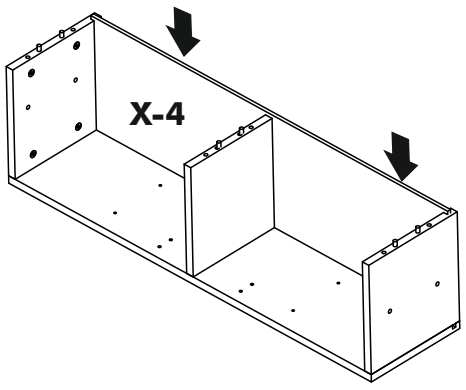

**STEP 24**

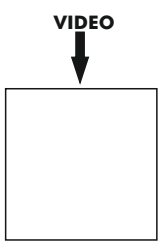
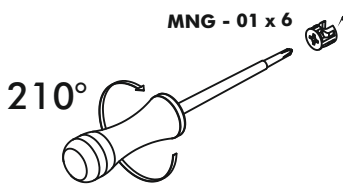
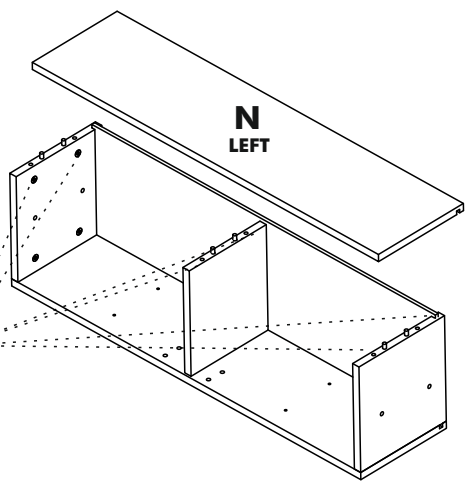

**STEP 25**

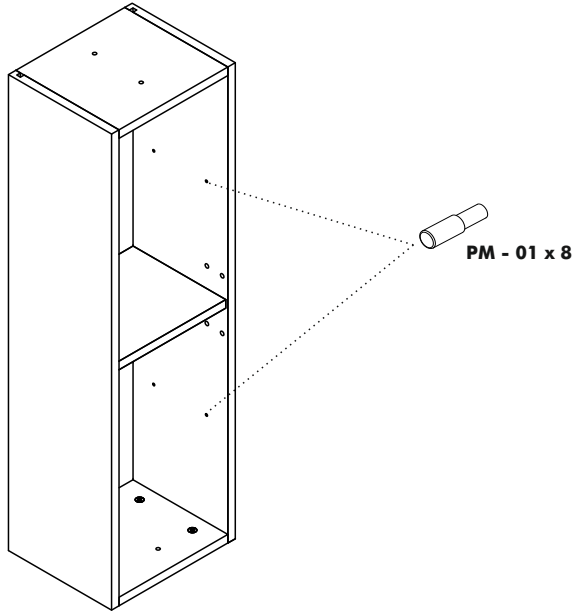

**STEP 26**

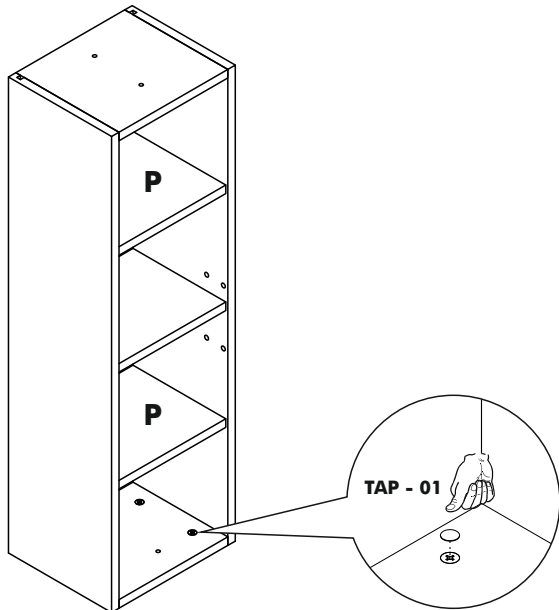

**STEP 27**

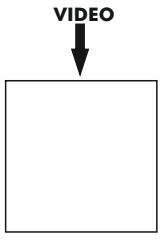
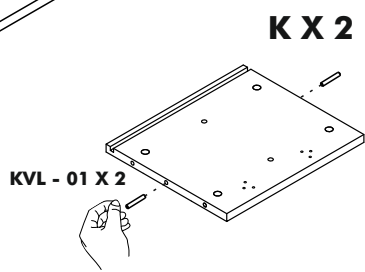
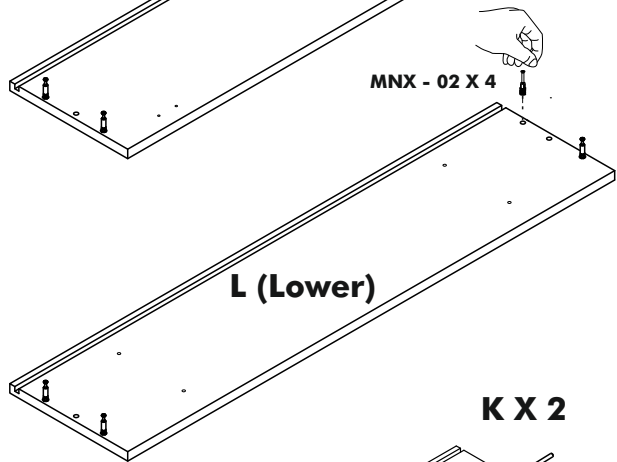
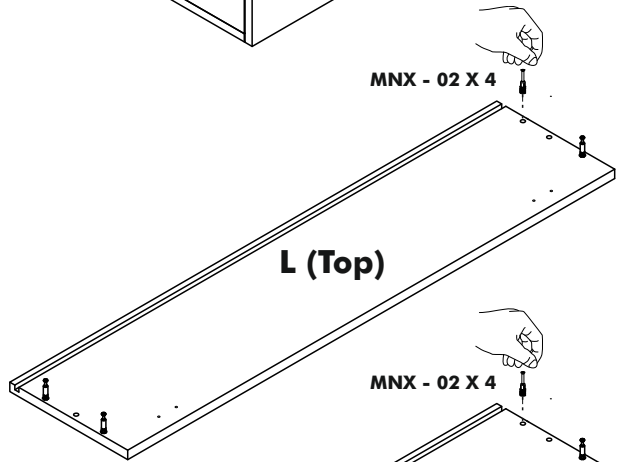
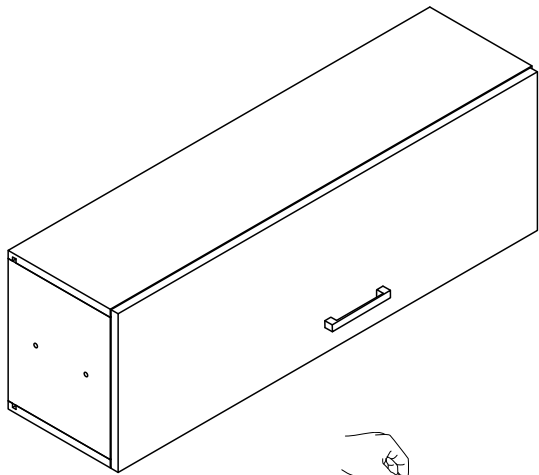
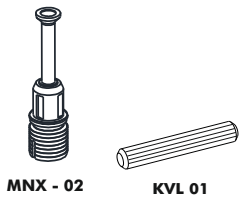

**STEP 28**



MNG - 01

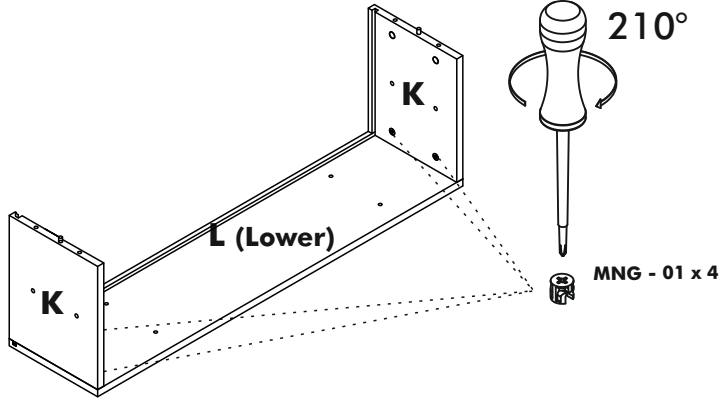

**STEP 29**

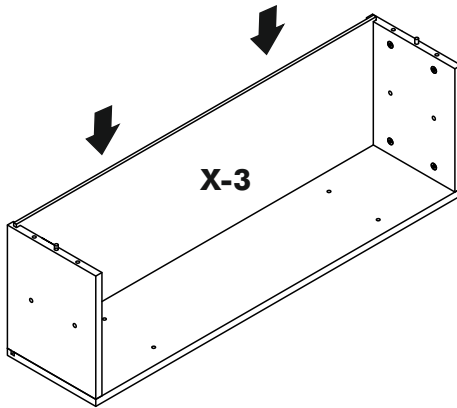

**STEP 30**



MNG - 01

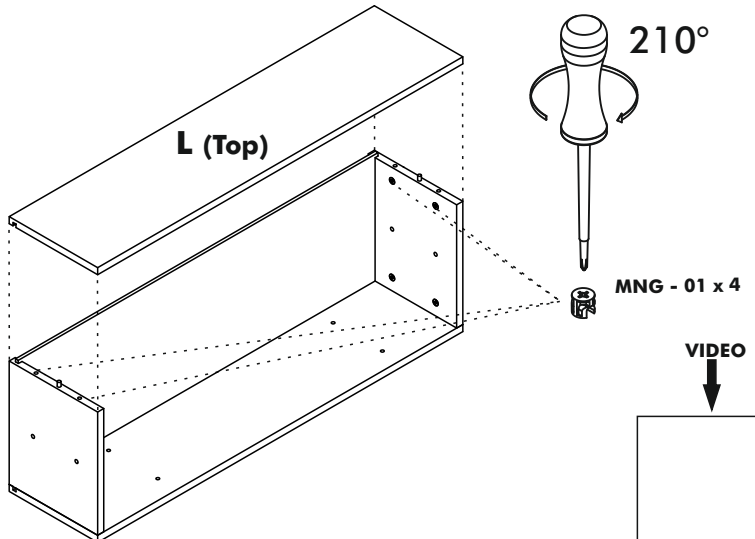

**VIDEO**

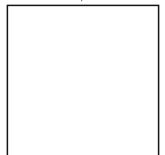

link

**STEP 31**

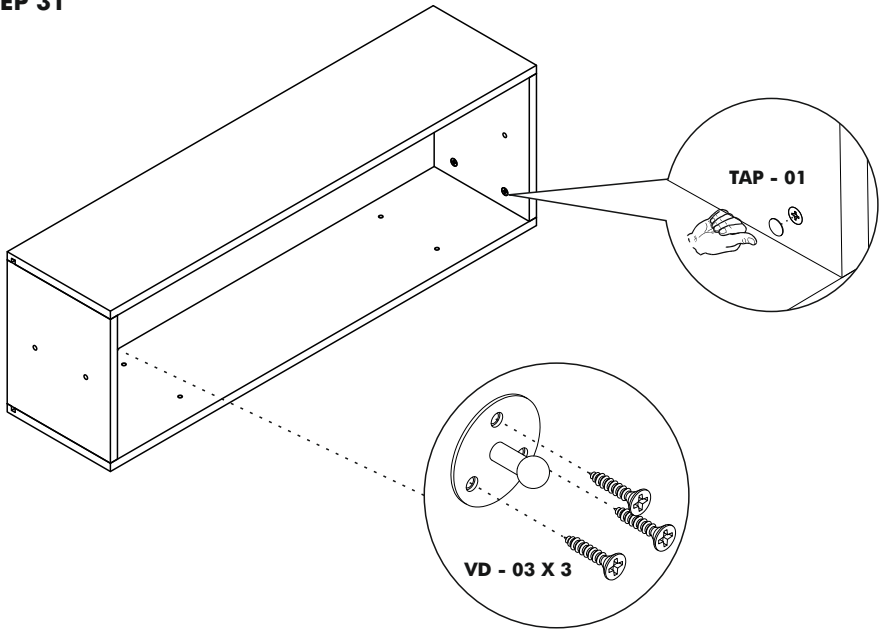

**STEP 32**

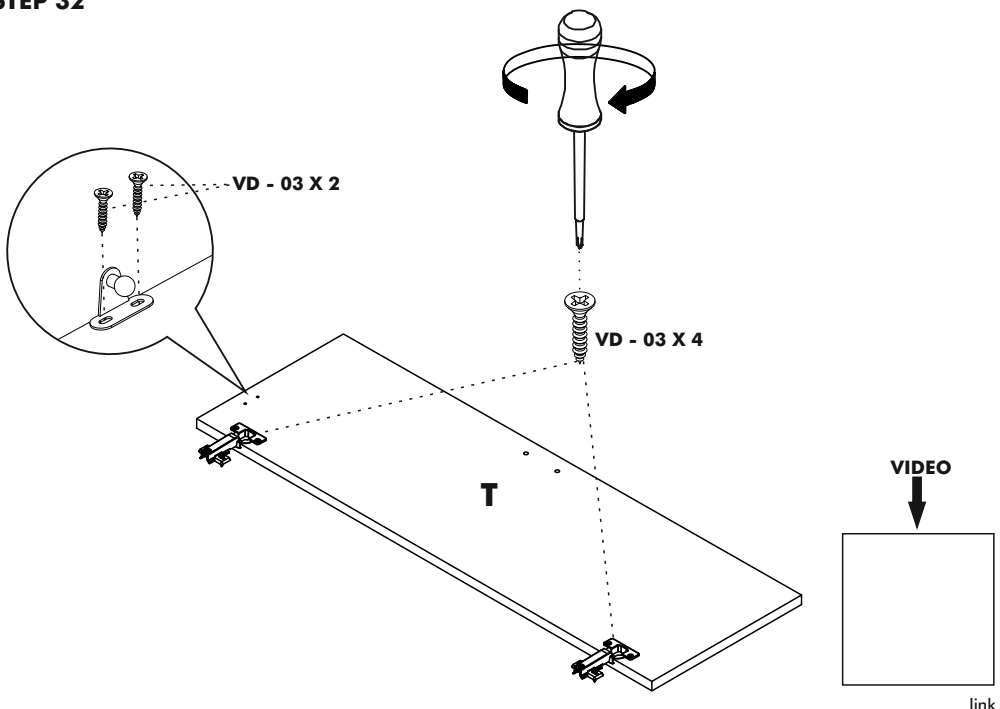

**STEP 33**

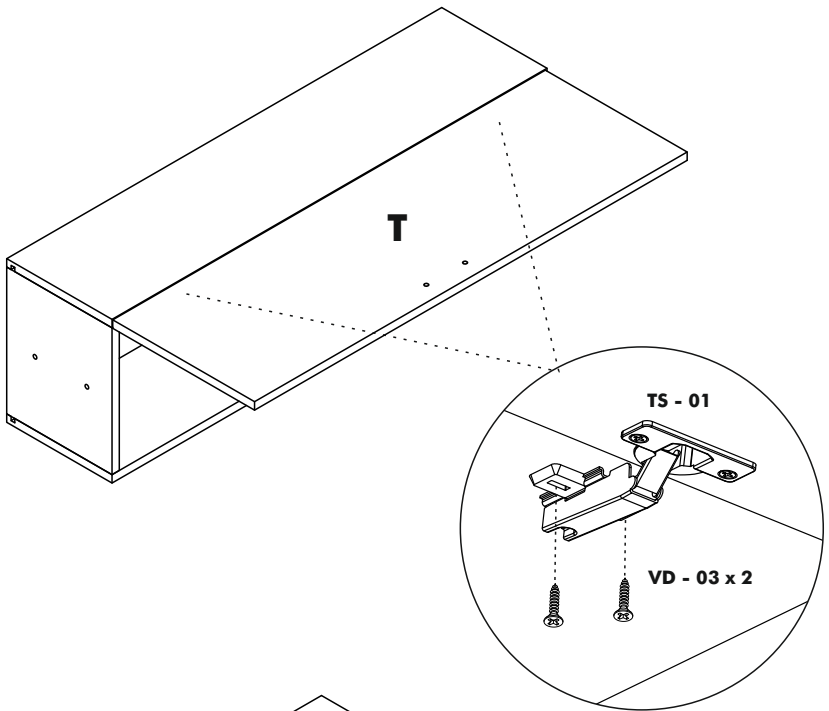

**STEP 34**

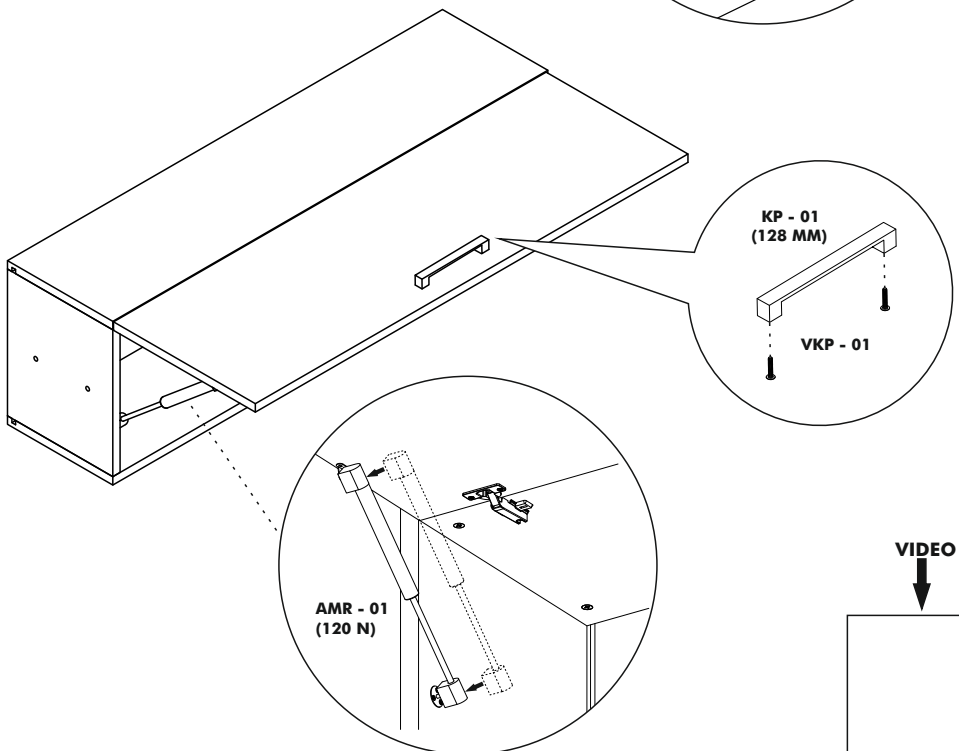

**VIDEO**

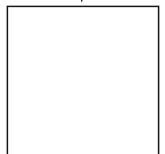

link



**STEP 35**

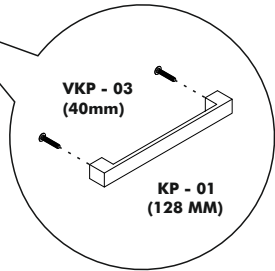
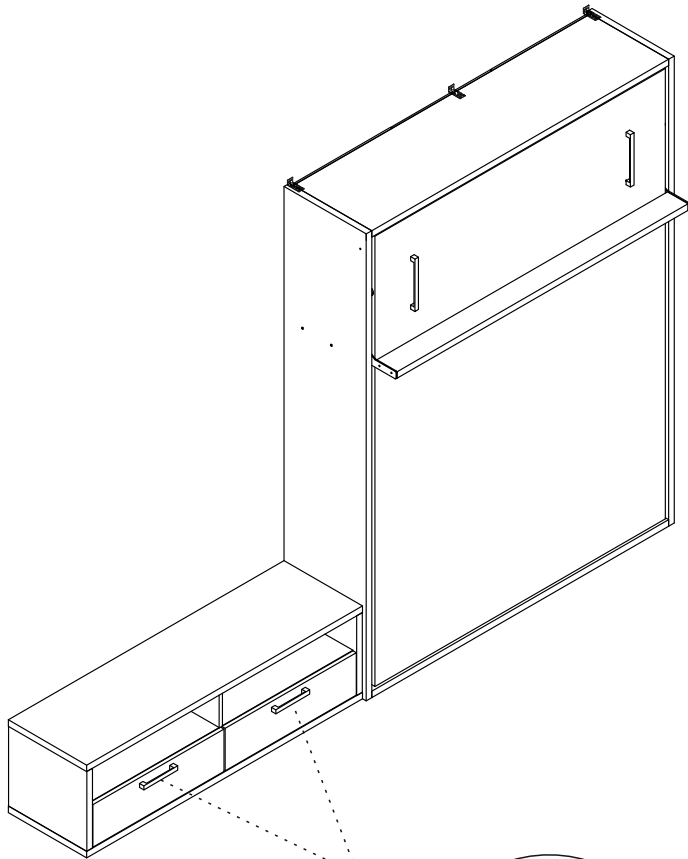

**VIDEO**

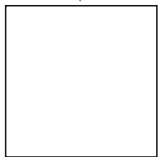

link

STEP 36

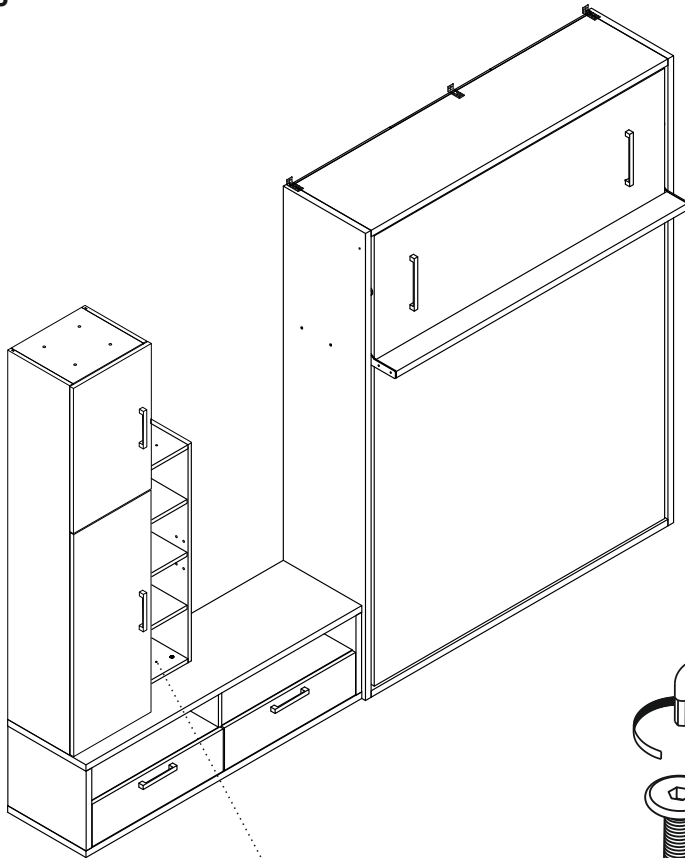

AL - 01

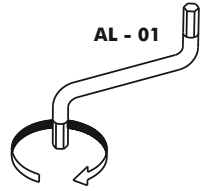

CT - 03 X 2

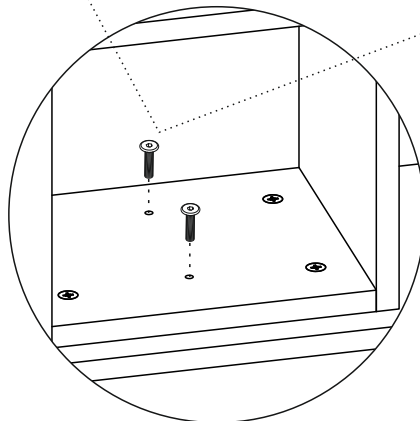
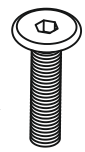

VIDEO

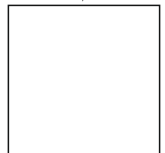

link

**STEP 37**

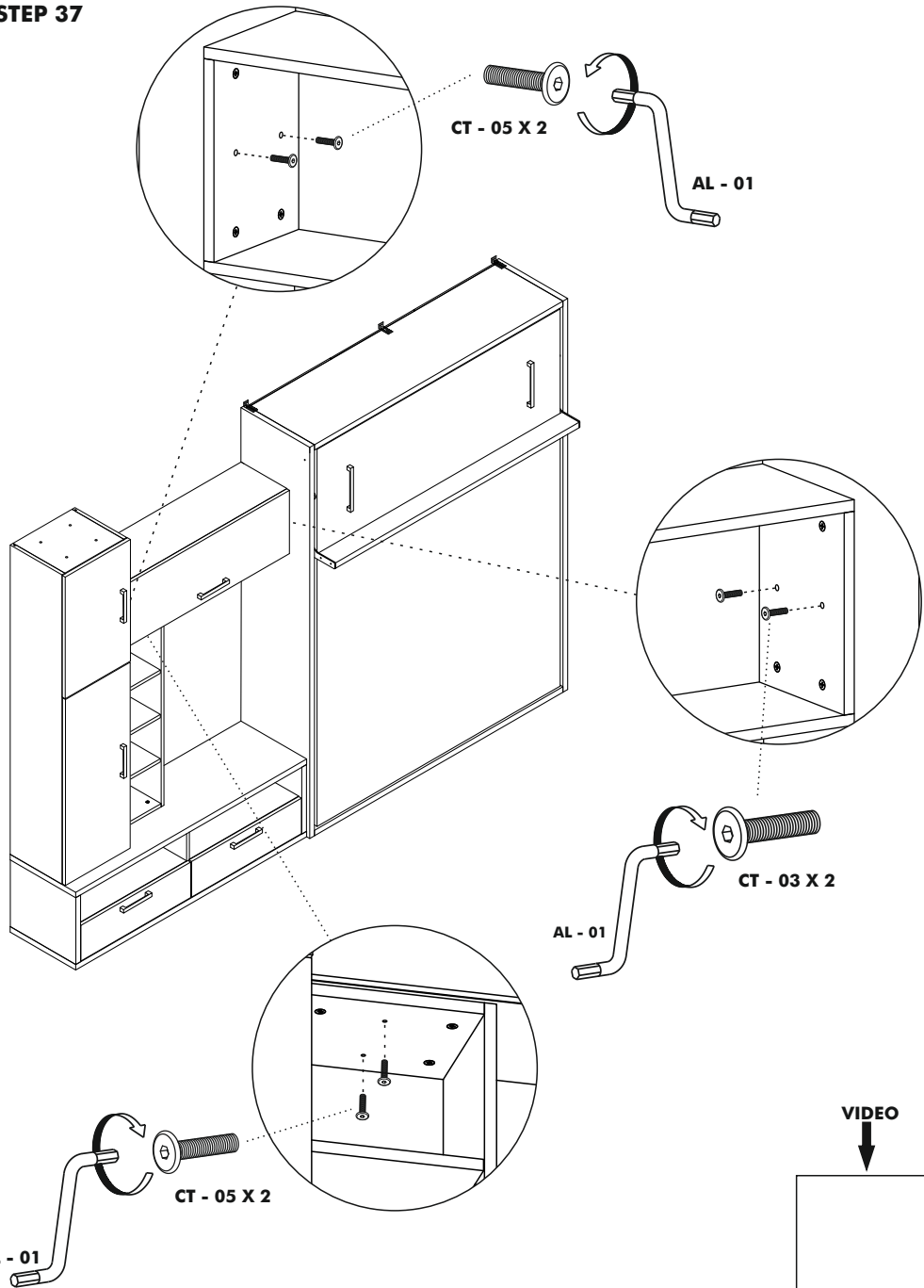

**CT - 05 X 2**

**AL - 01**

**CT - 03 X 2**

**AL - 01**

**CT - 05 X 2**

**AL - 01**

**VIDEO**

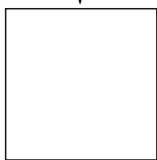

link

STEP 38

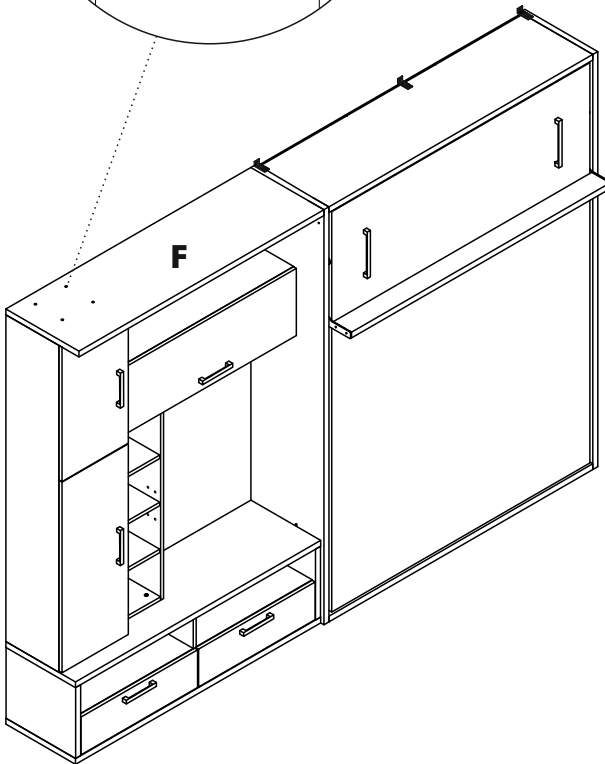
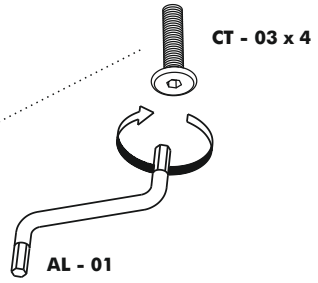
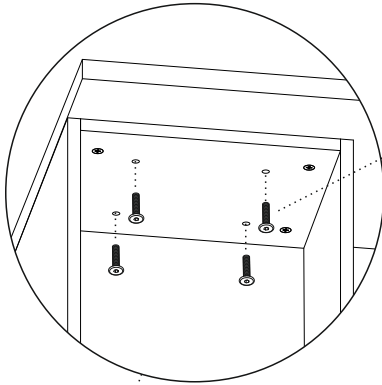

VIDEO

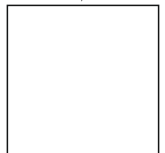

link

**STEP 39**

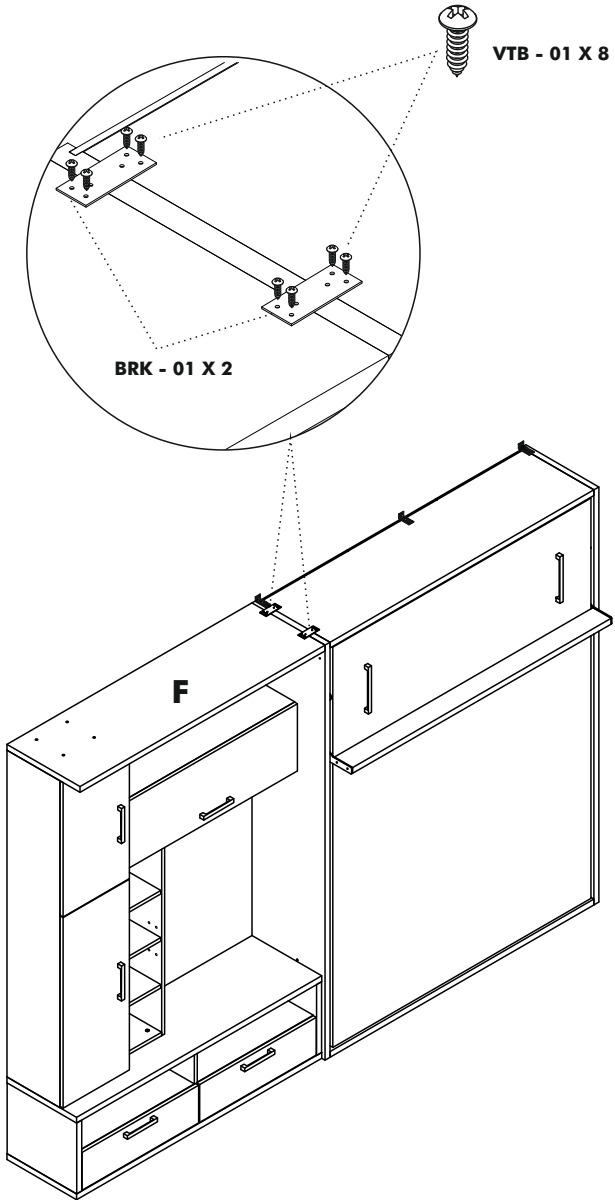

**VIDEO**

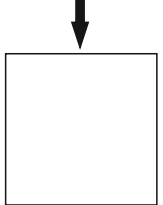

link

STEP 40

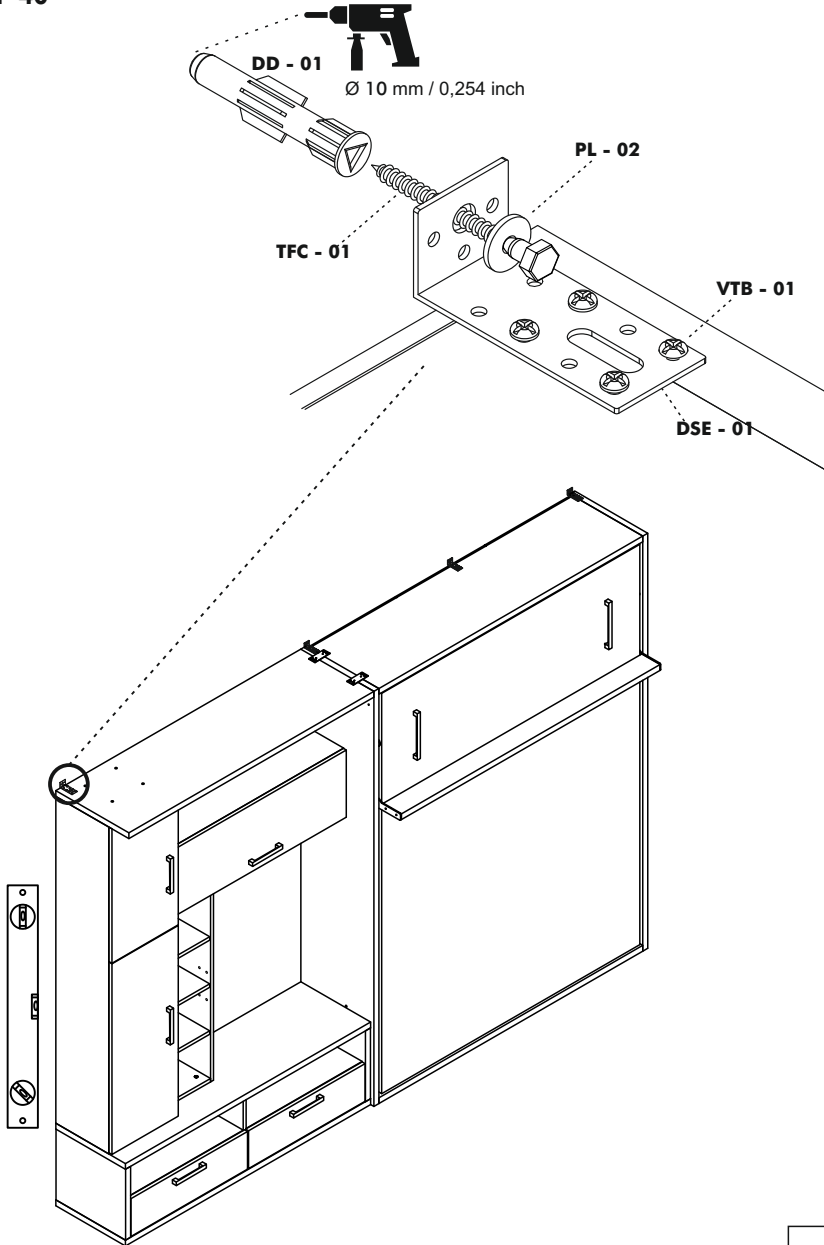

VIDEO

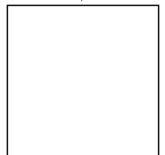

link

**STEP 41**

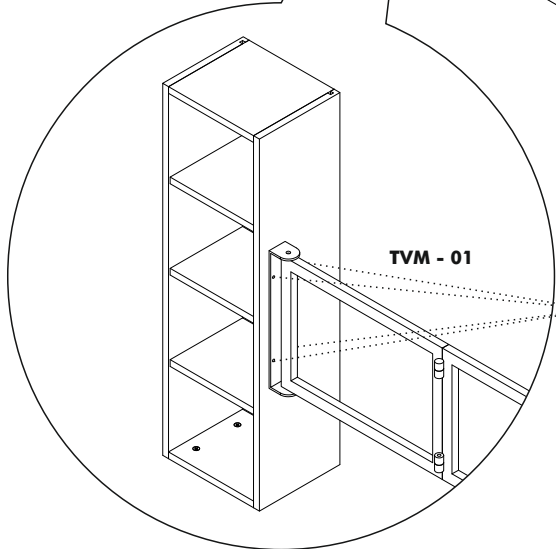
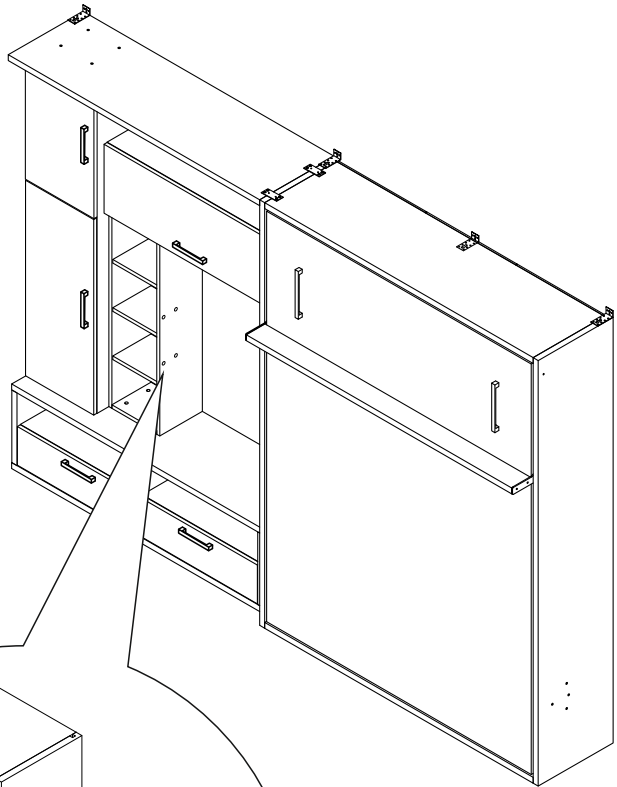

**TVM - 01**

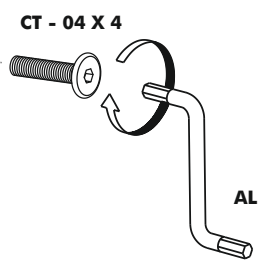

**AL - 01**

**VIDEO**

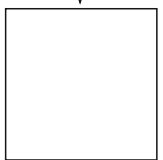

link

STEP 42

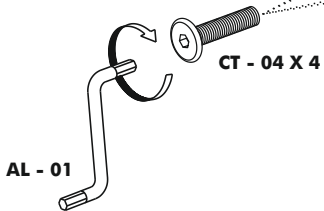
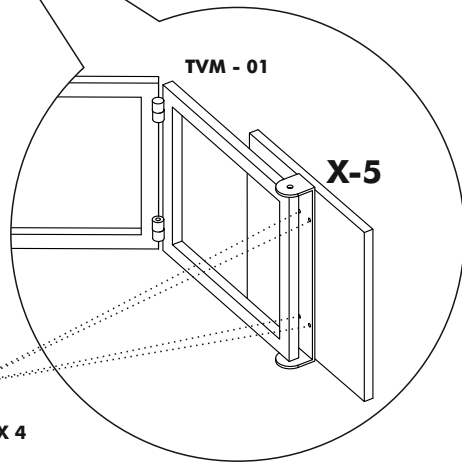
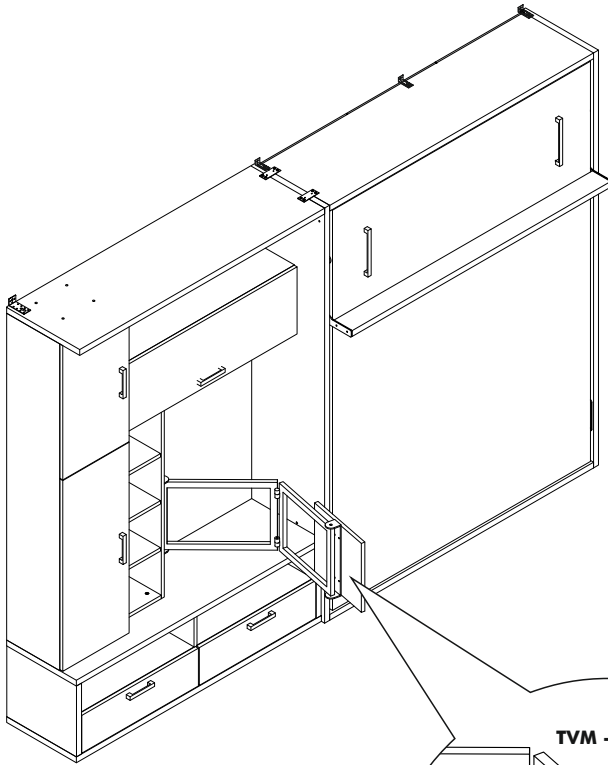

VIDEO  
↓

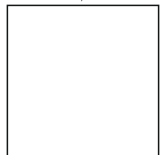

link



**STEP 43**

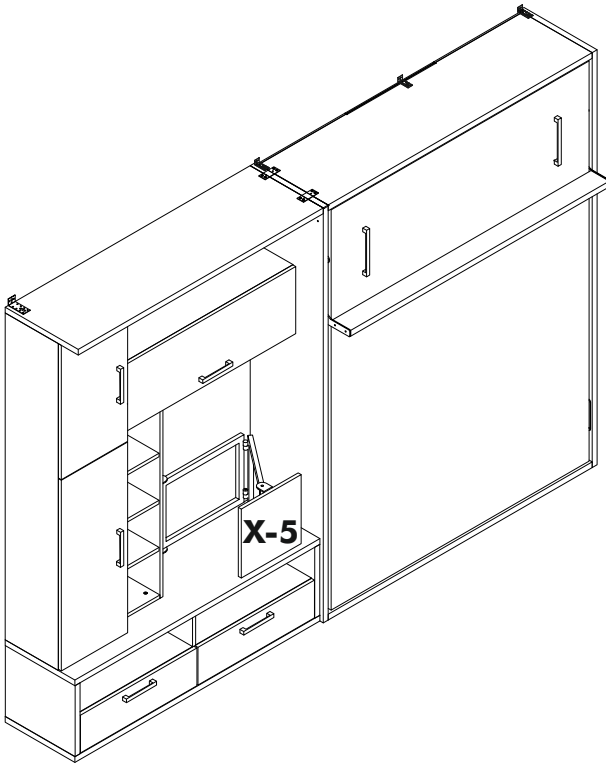

**VIDEO**

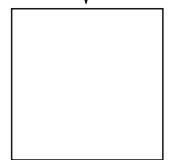

link

**STEP 44**

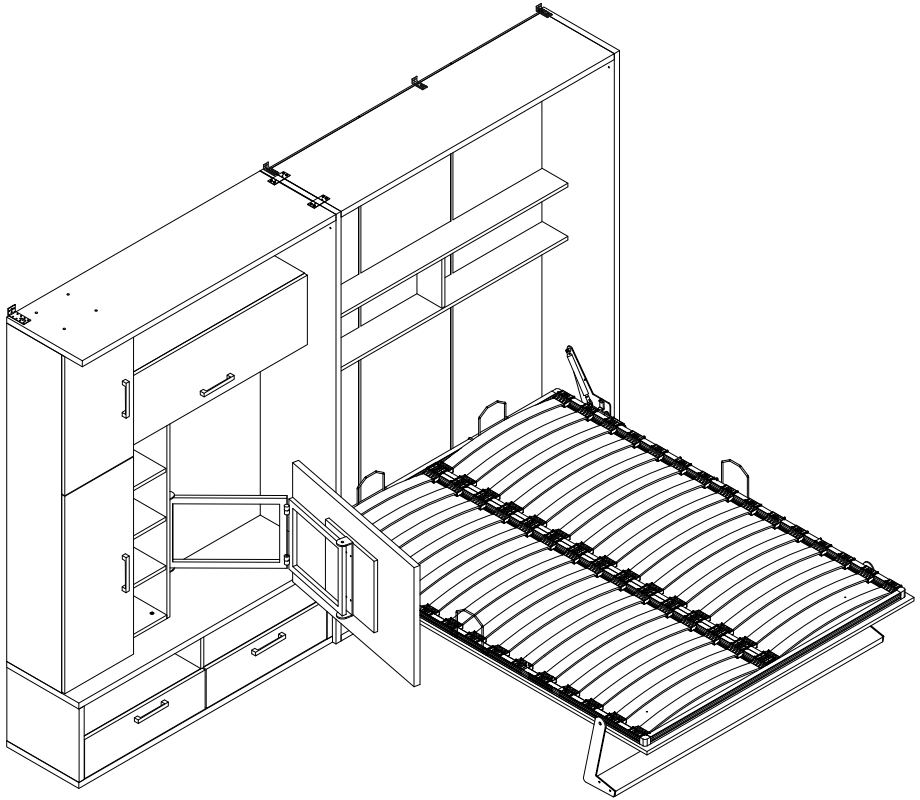

**VIDEO**

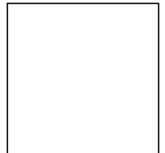

link

## ATTENTION / HOW TO / READ ME / OWNER'S GUIDE

1. When mounting on a regular drywall, furniture must be fastened to wood or metal studs. Solid walls made of brick, concrete or similar strong material are also acceptable. Do not mount furniture to paper-mache or sheet rock like material without properly affixing to stud.
2. For safety and product longevity you must periodically inspect the mounting and mechanical connections for integrity and tightness. Confirm hardware remains properly affixed and connections snug.
3. Wall Bed mattress thickness may not exceed 8 inch. Take care to remove pillows and excess blankets before closing. Doing so keeps mechanism free of obstruction and unnecessary stress.
4. Do not lean or rest heavy objects on side or top of furniture. This may cause balance issues and compromise the integrity of your mounting connections.
5. Please use the furniture's beds, desks and shelving as intended. Not designed to be sat, stood, leaned, jumped (etc) on. Improper use may cause personal injury and damage to property.
6. With seasonal humidity change you must inspect interior and exterior of furniture.
7. Single, Twin, Twin XL beds accommodate the weight of one person. Improperly sleeping more than one person risks injury to person and damage to property.
8. Before any un-mounting or disassembly please contact Multimo for technical support and instruction. Failure to properly detach risks injury to person and damage to property.
9. For Bunk Beds:
  - a. Always use provided ladder when accessing top bunk.
  - b. Be slow, careful and aware of surroundings when opening top bunk.
  - c. Do not horseplay. Beds are to be slept on only.
  - d. Some have legs that fully extend when open- be aware of where the leg is and will be.



**MULTiMO**

[www.multimo.com](http://www.multimo.com)