

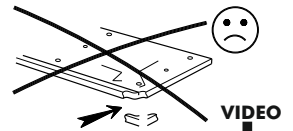

# MULTIMO

## 113 STUDIO 5 LEFT

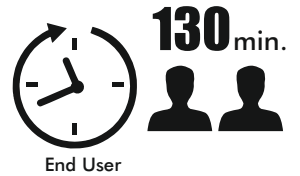
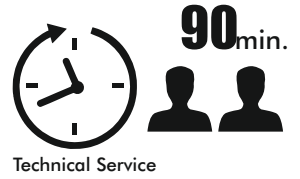
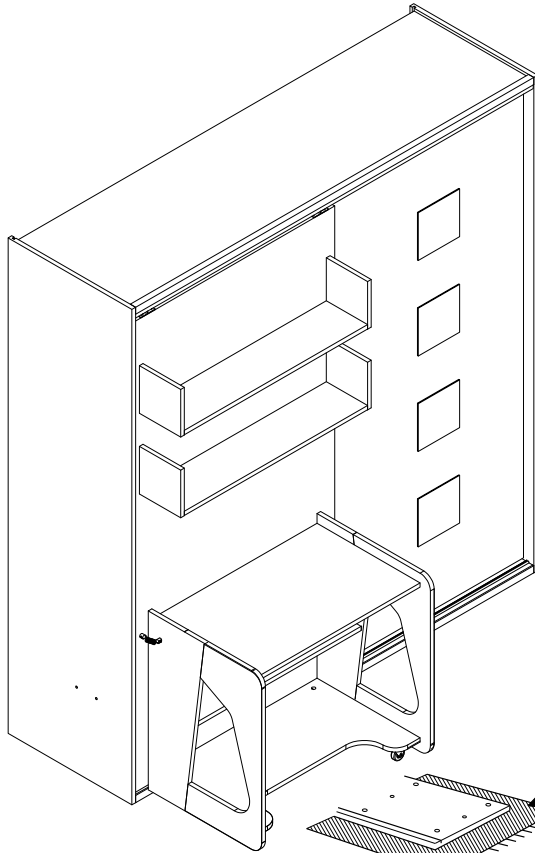

VIDEO

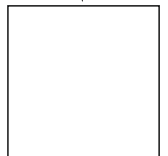



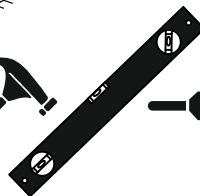
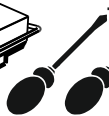
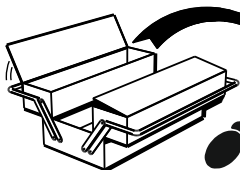





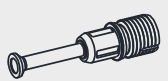

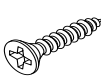
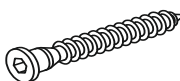
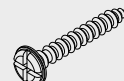
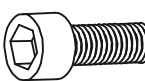
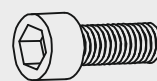





link

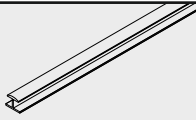

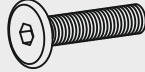
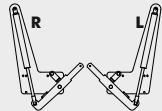
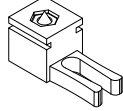
| Track Title | (inch) |           |        | (mm)  |       |       |        |      |
|-------------|--------|-----------|--------|-------|-------|-------|--------|------|
|             | Piece  | Thickness | Length | Width | Piece | Thick | Height | Most |
| A           |        | 1,18      | 81,89  | 23,62 | 2     | 30    | 2080   | 600  |
| B           |        | 0,71      | 75,98  | 23,62 | 1     | 18    | 1930   | 600  |
| C           |        | 0,71      | 75,98  | 22,83 | 1     | 18    | 1930   | 580  |
| D           |        | 0,71      | 79,53  | 19,29 | 1     | 18    | 2020   | 490  |
| E           |        | 0,71      | 37,64  | 18,50 | 3     | 18    | 956    | 470  |
| F           |        | 0,71      | 37,64  | 7,48  | 2     | 18    | 956    | 190  |
| G           |        | 0,71      | 7,87   | 18,31 | 2     | 18    | 200    | 465  |
| H           |        | 0,71      | 13,78  | 18,50 | 2     | 18    | 350    | 470  |
| I           |        | 0,71      | 37,64  | 5,12  | 2     | 18    | 956    | 130  |
| K           |        | 0,71      | 9,84   | 4,92  | 1     | 18    | 250    | 125  |
| L           |        | 0,71      | 11,42  | 18,66 | 2     | 18    | 290    | 474  |
| M           |        | 0,71      | 31,50  | 20,47 | 1     | 18    | 800    | 520  |
| N           |        | 0,71      | 31,50  | 13,78 | 1     | 18    | 800    | 350  |
| O           |        | 0,71      | 31,50  | 7,68  | 1     | 18    | 800    | 195  |
| P           |        | 0,71      | 31,50  | 20,47 | 1     | 18    | 800    | 520  |
| R           |        | 0,71      | 29,53  | 10,59 | 2     | 18    | 750    | 269  |
| S           |        | 0,71      | 29,53  | 14,76 | 2     | 18    | 750    | 375  |
| T           |        | 0,71      | 77,87  | 38,19 | 2     | 18    | 1978   | 970  |
| U           |        | 0,71      | 32,28  | 7,68  | 2     | 18    | 820    | 195  |
| Y           |        | 0,71      | 7,87   | 7,87  | 4     | 18    | 200    | 200  |
| Z           |        | 6,61      | 32,13  | 16,54 | 2     | 168   | 816    | 420  |
| X           |        | 0,31      | 81,06  | 19,13 | 4     | 8     | 2059   | 486  |

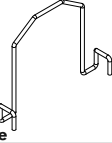
### Accessories List

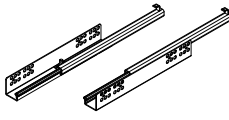
|  |  |   |   |
|--|--|---|---|
| <b>MXN 02</b><br><br><b>70 / piece</b>                | <b>MNG - 01</b><br><br><b>70 / piece</b>            | <b>KVL 01</b><br><br><b>84 / piece</b>           | <b>VD - 03 ( 3,5x18 ) mm</b><br><br><b>20 / piece</b> |
| <b>VDA - 01 ( 6,5x50 ) mm</b><br><br><b>6 / piece</b> | <b>VD - 02 (3,5x25) mm</b><br><br><b>46 / piece</b> | <b>IM - 04 (6x20) mm</b><br><br><b>2 / piece</b> | <b>IM - 01 (6x30) mm</b><br><br><b>2 / piece</b>      |
| <b>OT 01</b><br><br><b>4 / piece</b>                  | <b>TS - 03</b><br><br><b>4 / piece</b>              | <b>AF - 02</b><br><br><b>2 / piece</b>           | <b>BO - 01</b><br><br><b>1 / piece</b>                |

|   |  |   |  |
|---|--|---|--|
| <b>YY 01</b><br><br><b>2 / piece</b>               | <b>H 01</b><br><br><b>3 / piece</b>     | <b>AVT - 01</b><br><br><b>10 / piece</b> | <b>CT - 07 ( 6x15 ) mm</b><br><br><b>8 / piece</b> |
| <b>MKZ - 01</b><br><br><b>2 / piece</b> <b>450N</b> | <b>STP - 01</b><br><br><b>4 / piece</b> | <b>TAP - 01</b><br><br><b>70 / piece</b> | <b>TTC 01</b><br><br><b>4 / piece</b>              |
| <b>TSY - 01</b><br><br><b>2 / piece</b>            | <b>TKR - 01</b><br><br><b>4 / piece</b> | <b>RYP - 02</b><br><br><b>2 / piece</b>  | <b>ER - 01</b><br><br><b>8 / piece</b>              |

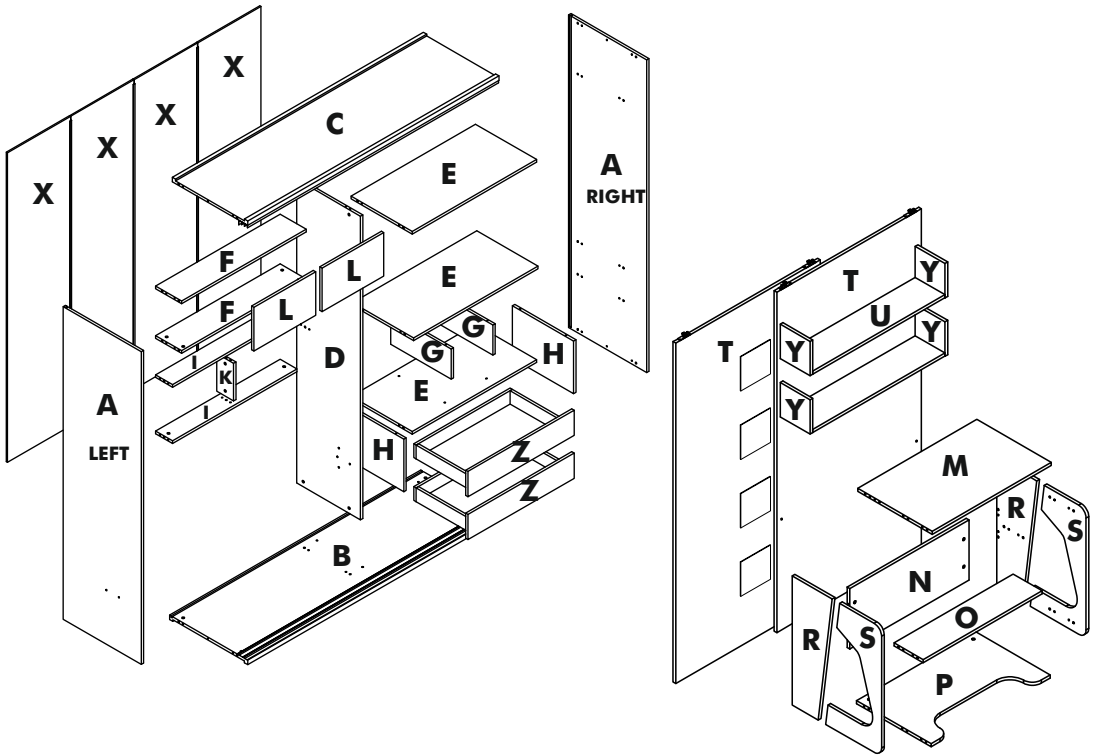

**STEP 1**



MNX - 02

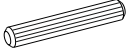

KVL 01

**NOT; MNX-02 SIKABİLMEK İÇİN ÖNCE RAY SÖKÜLÜR.  
MNX-02 SIKIMI BİTİMİ İLE ( STEP 11 )  
RAY GERİ MONTE EDİLİR.**

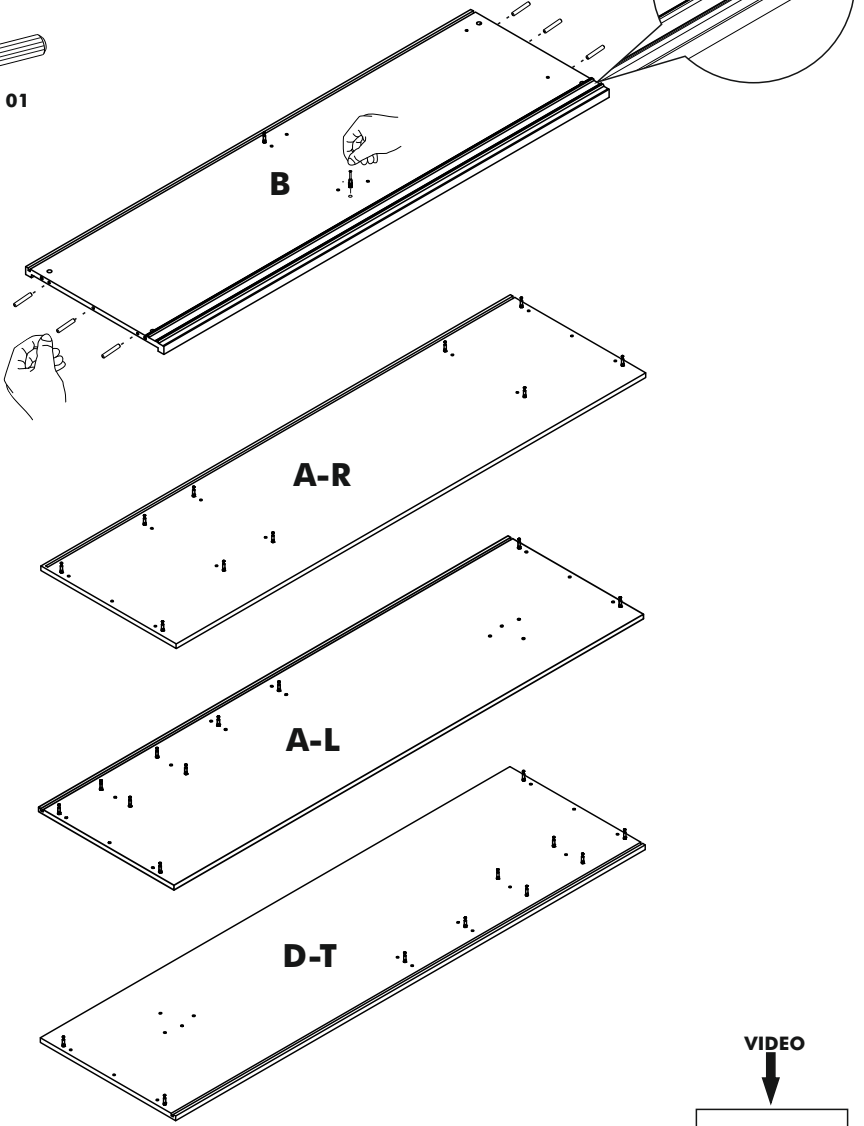

**VIDEO**

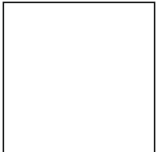

link

**STEP 2**

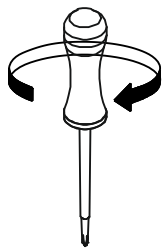
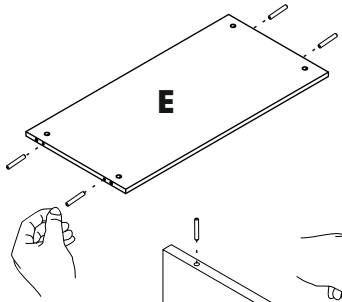
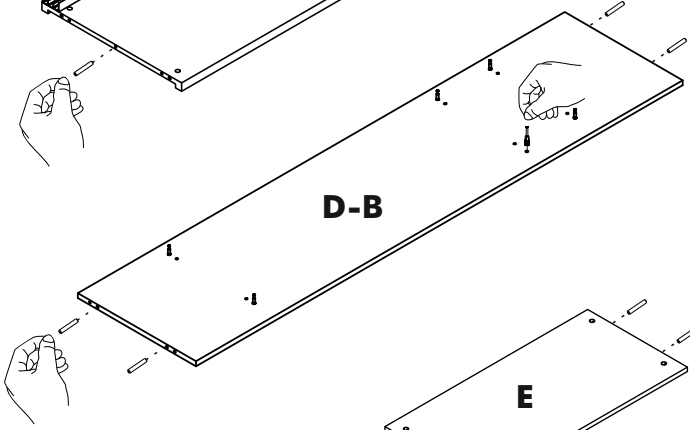
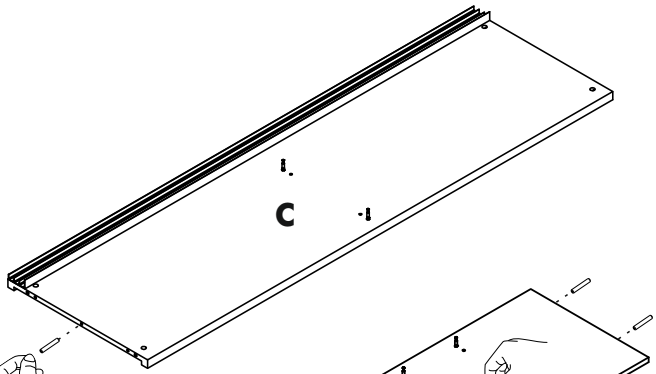
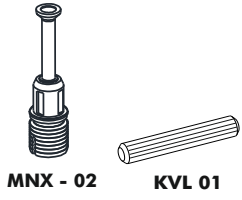

**G-L/G R**

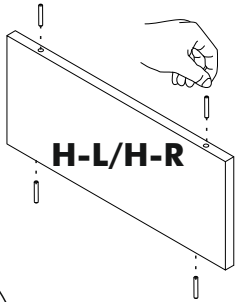
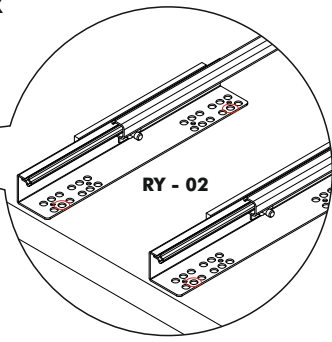
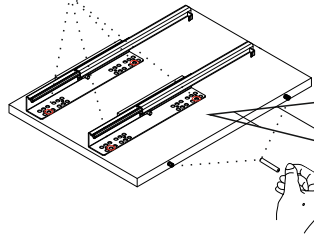

**VIDEO**

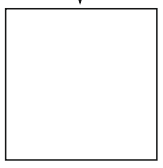

link

**STEP 3**

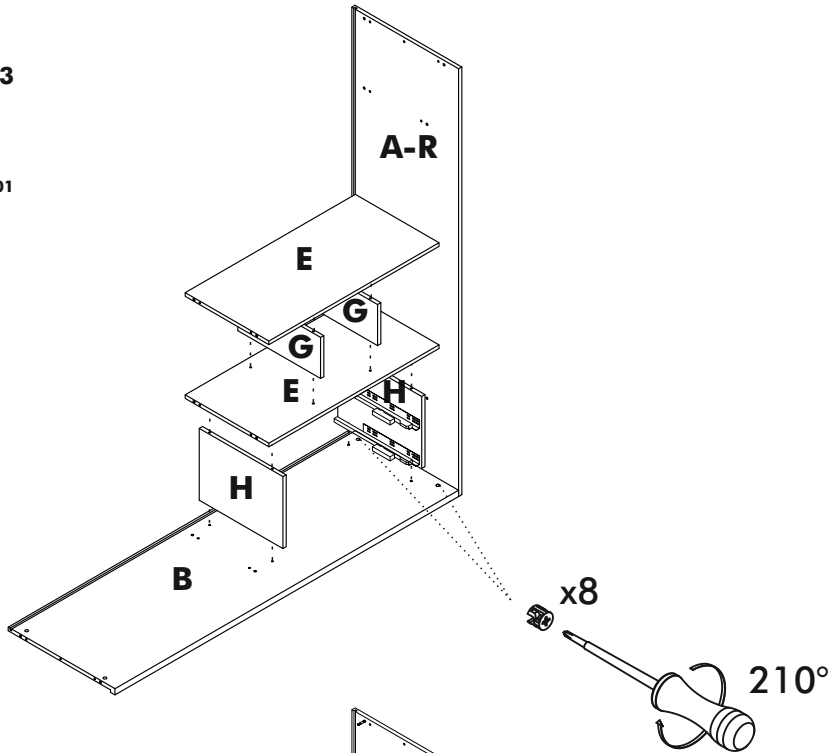

**STEP 4**

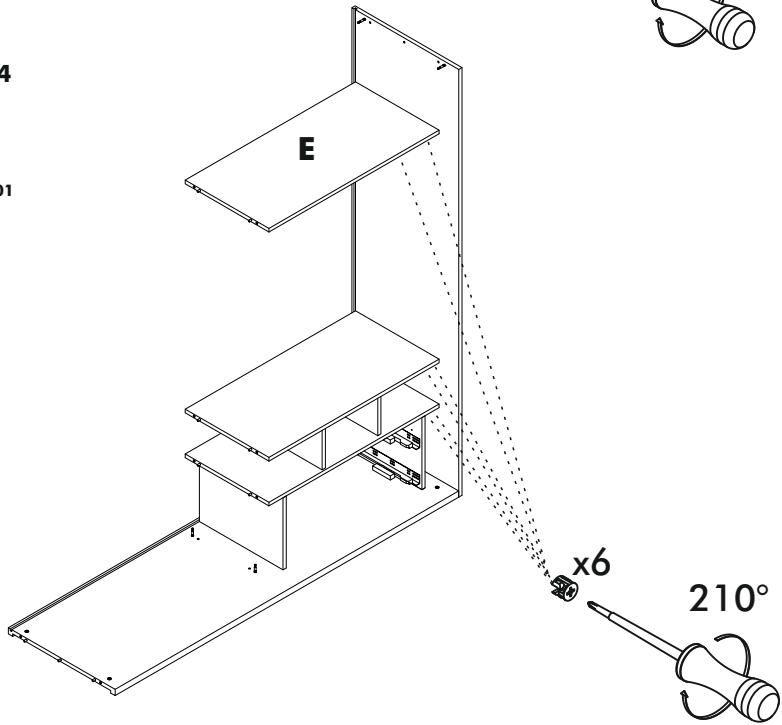

**VIDEO**

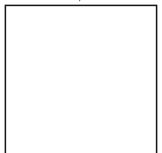

link

**STEP 5**



MNG - 01

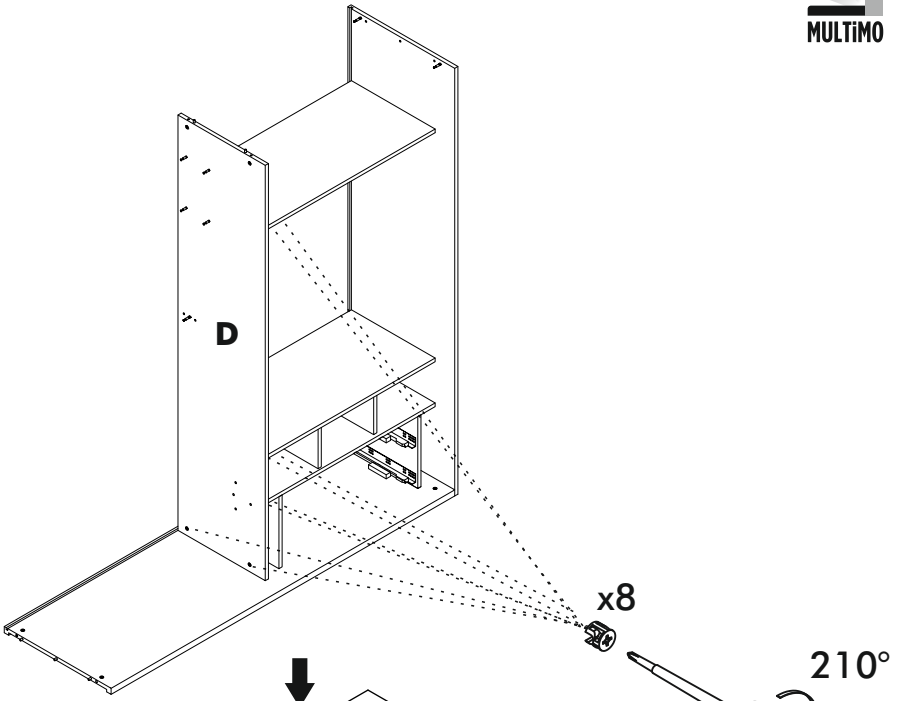

**STEP 6**



MNG - 01

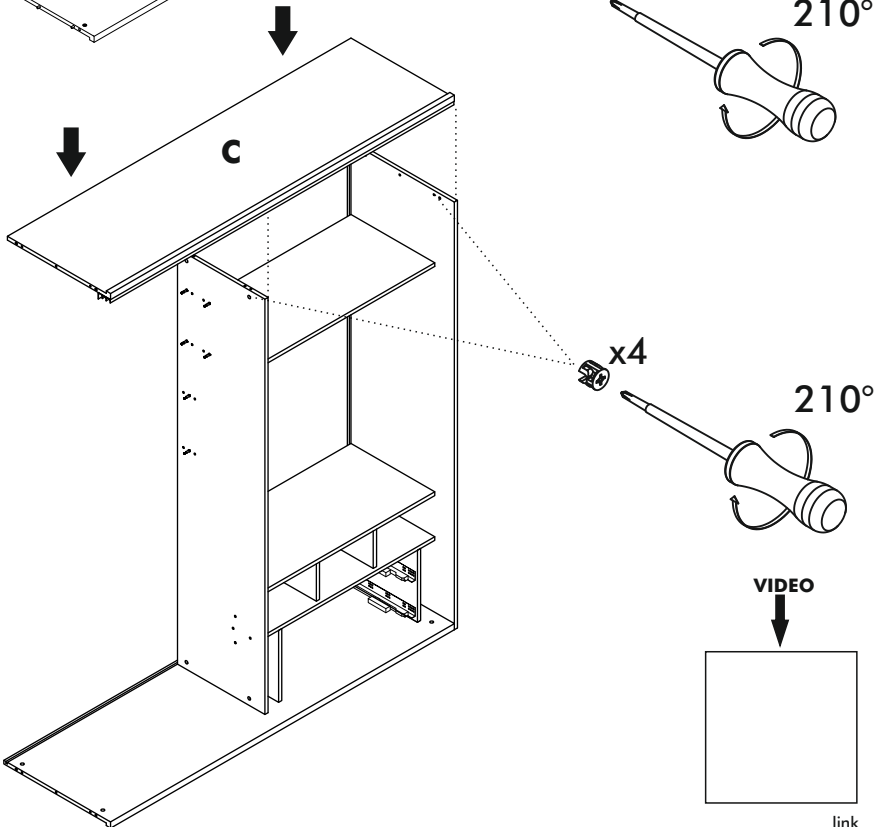

**VIDEO**

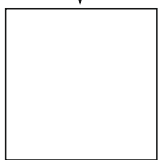

link

**STEP 7**

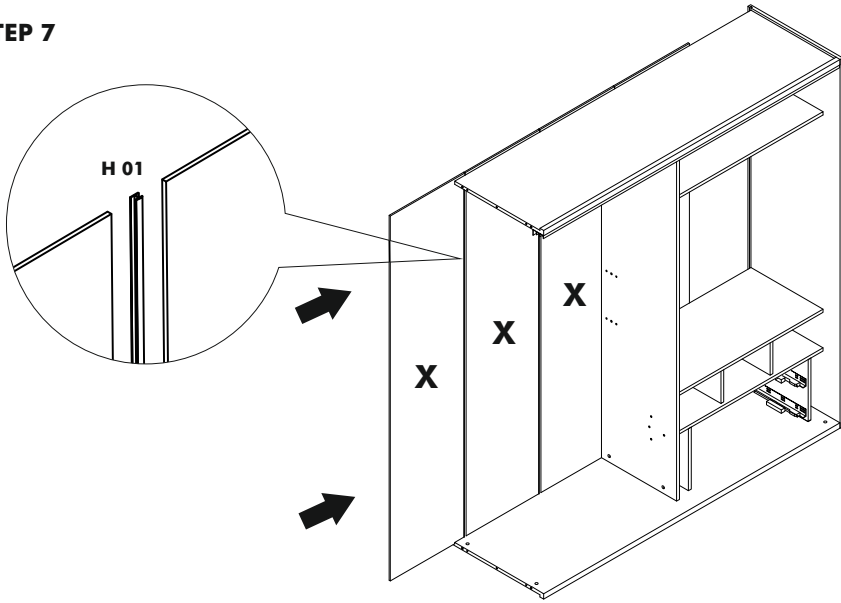

**STEP 8**

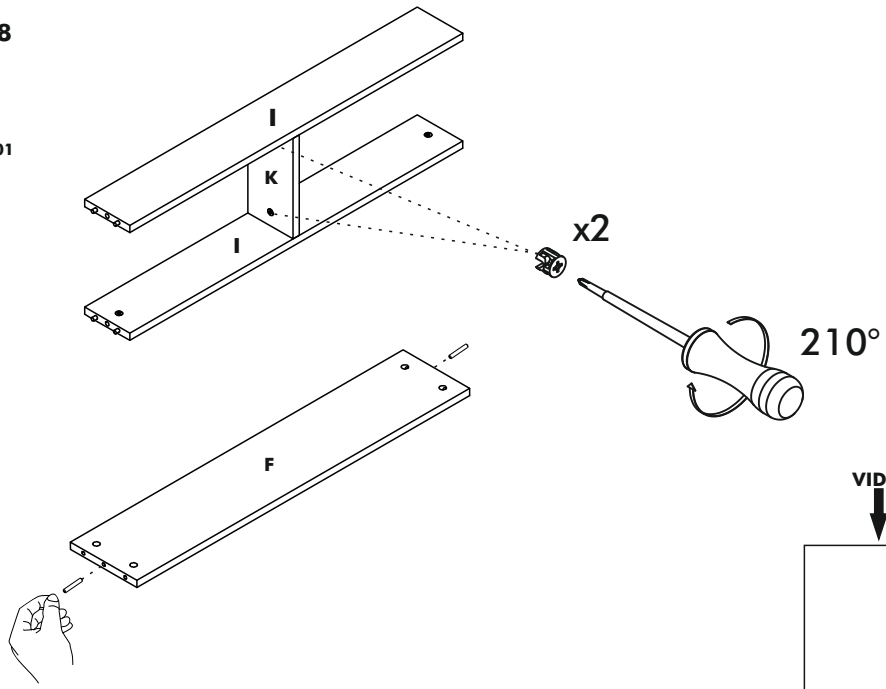



**STEP 9**



SPT - 01



MNG - 01

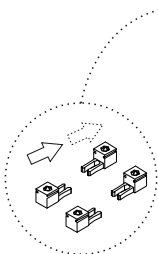

SPT-01 X 4

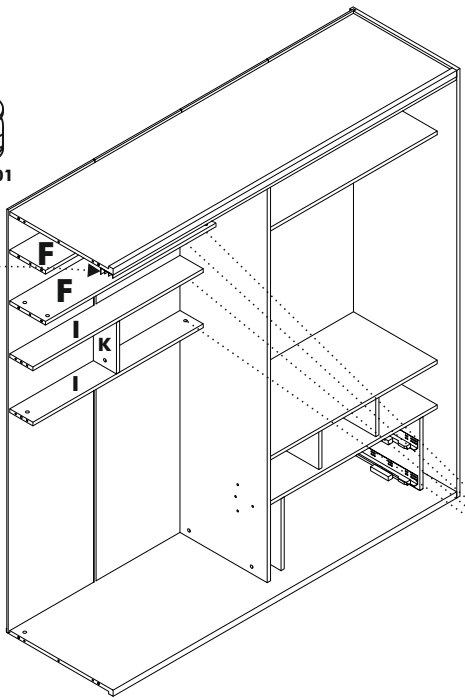

x6

210°

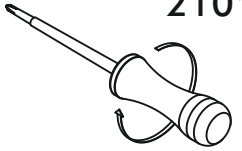

**STEP 10**

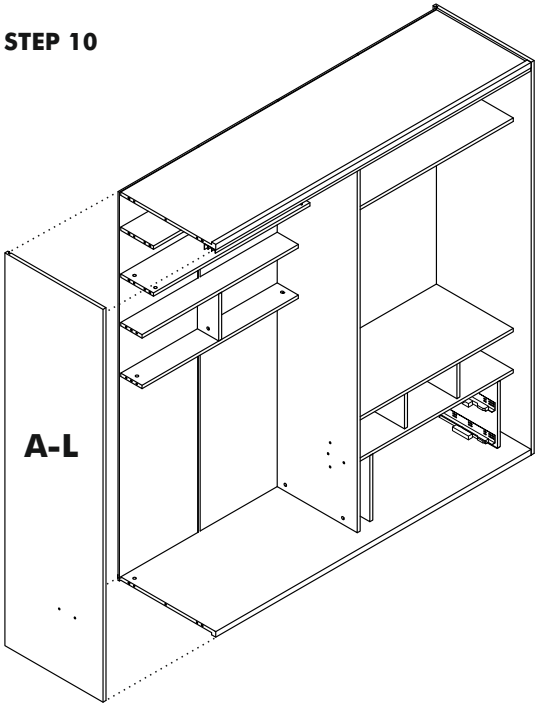

A-L

VIDEO

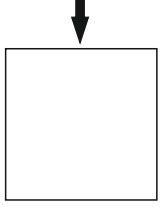

link

**STEP 11**

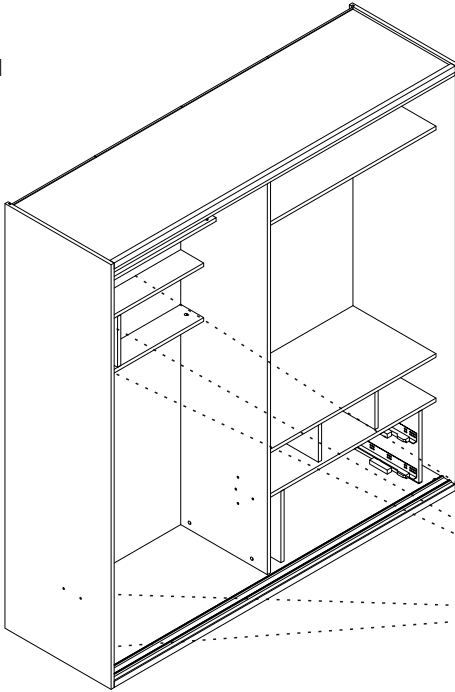

x10

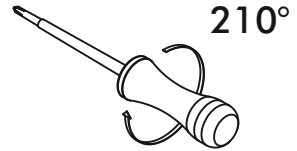

**STEP 12**

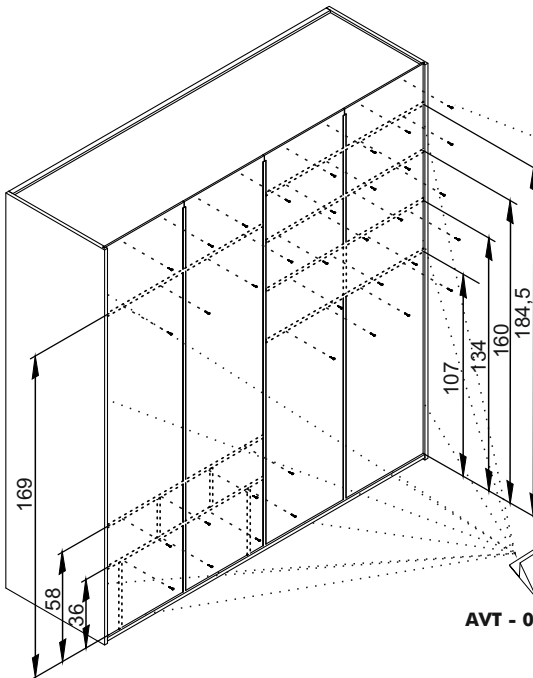

VD - 02 x 36

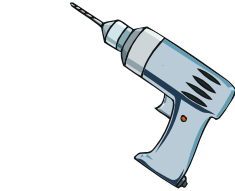

VD - 02 x 10

AVT - 01 x 10

VIDEO

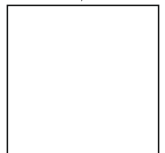

link

**STEP 13**

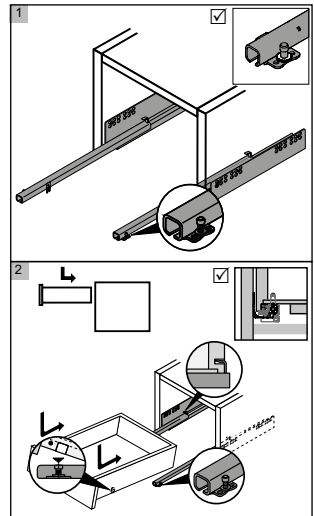
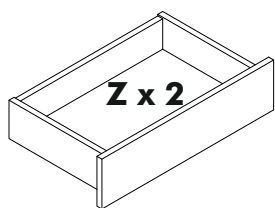
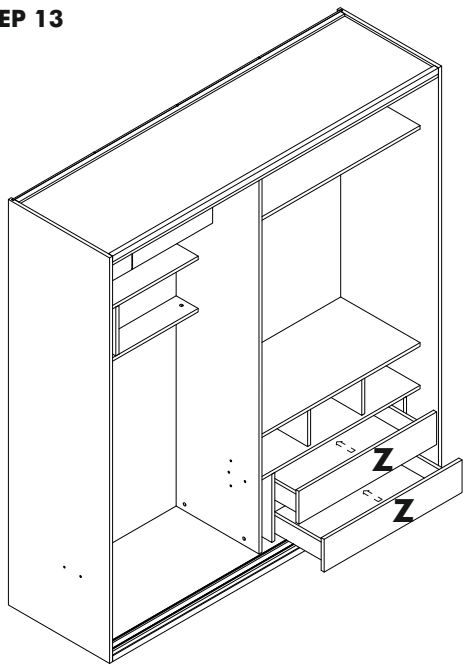

**STEP 14**

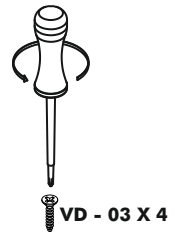
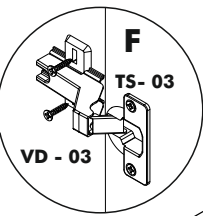
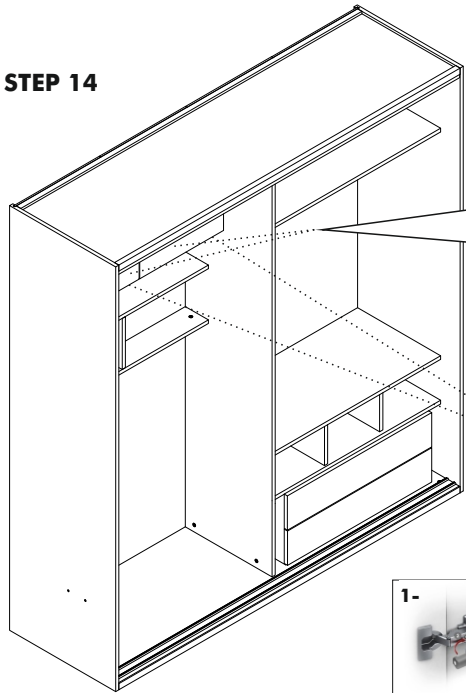

**VIDEO**  
↓

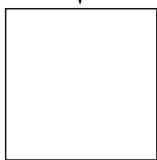
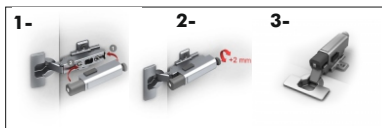

**STEP 15**

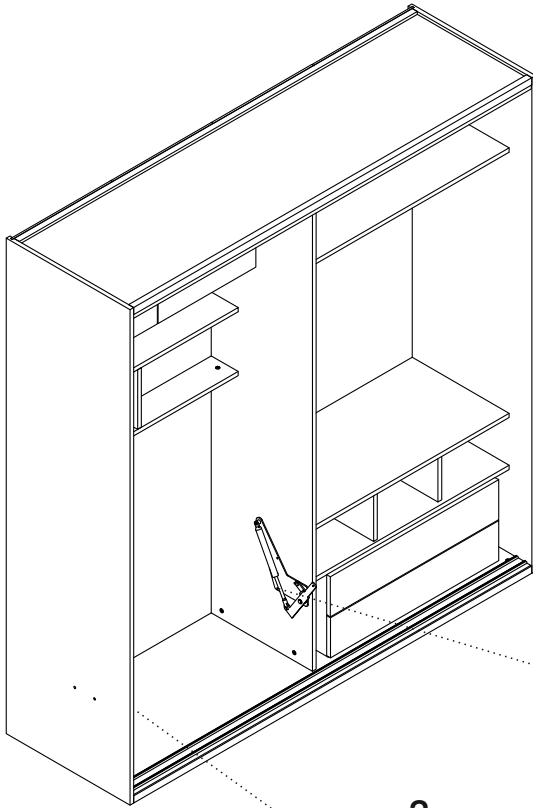

**CAUTION**  
**DO NOT UNLOCK BEFORE INSTALL**

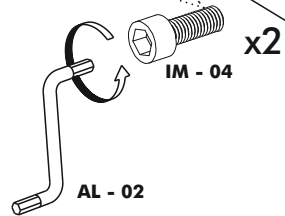
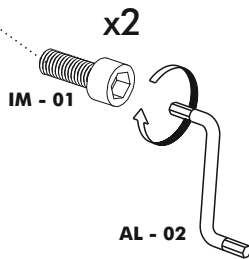
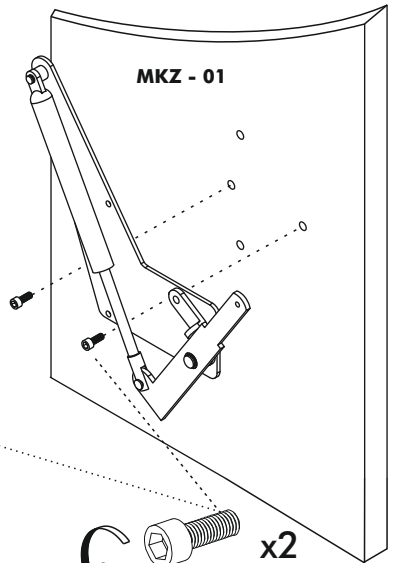

**VIDEO**

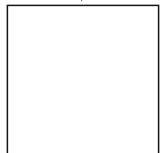

link

**STEP 16**

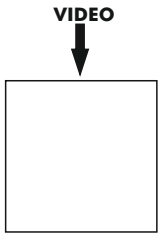
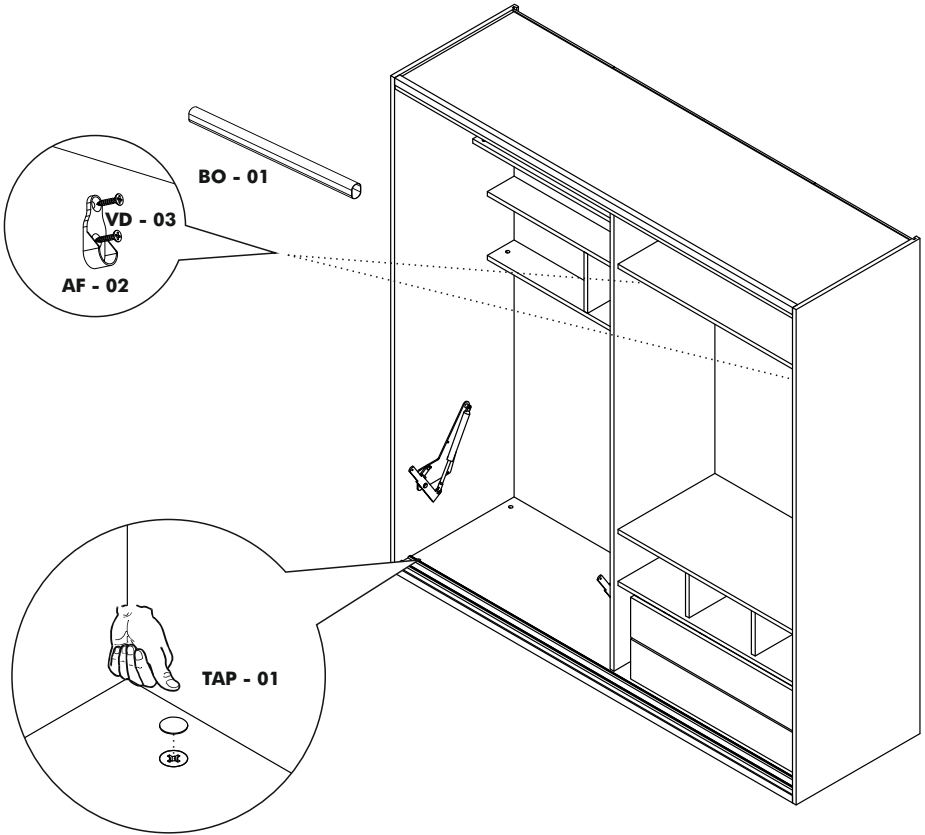

STEP 17

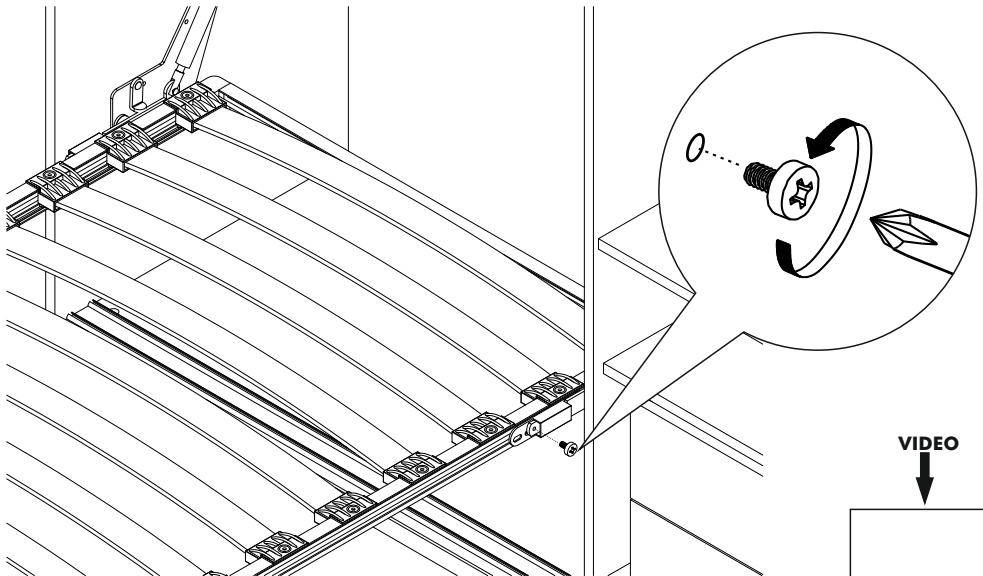
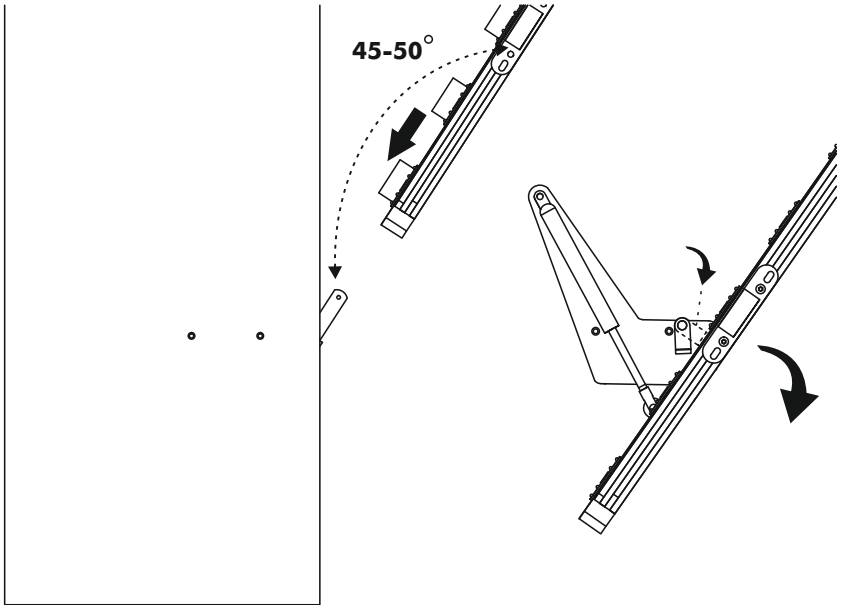

**STEP 18**



MNG - 01

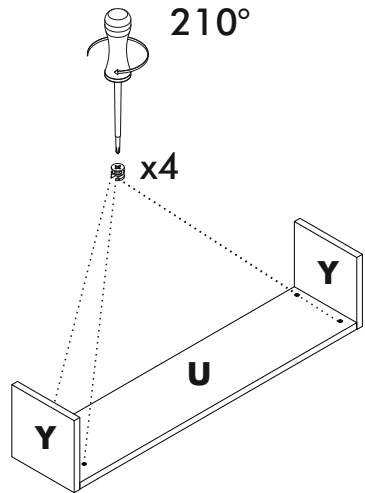
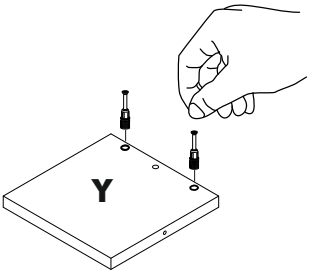

**STEP 19**

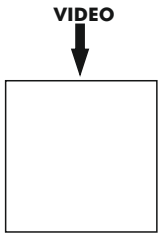
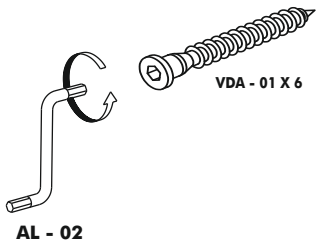
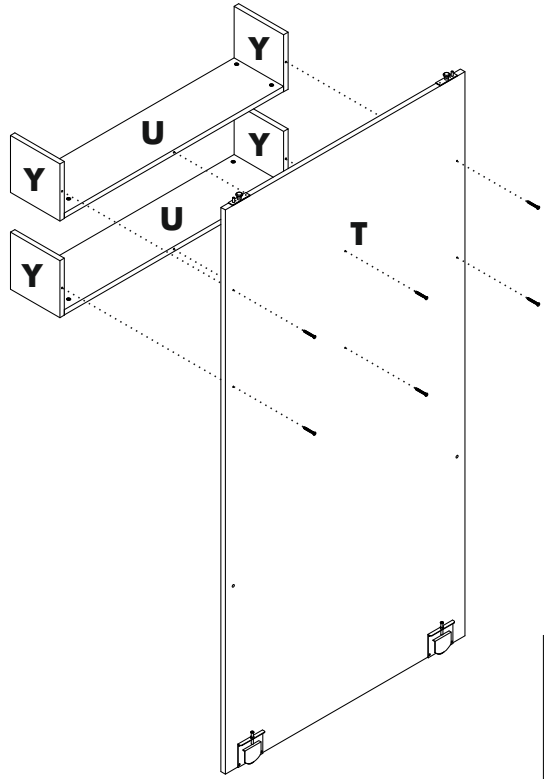

**STEP 20**

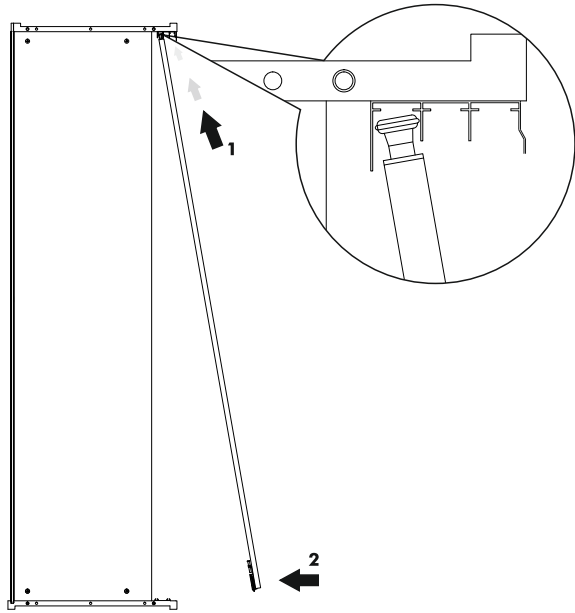

**STEP 21**

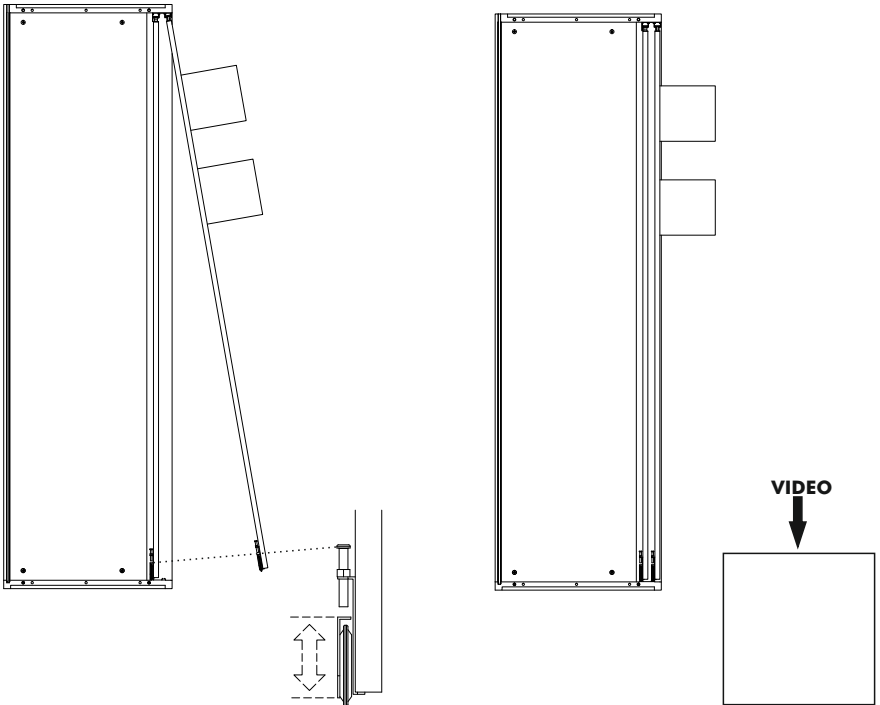



**STEP 22**

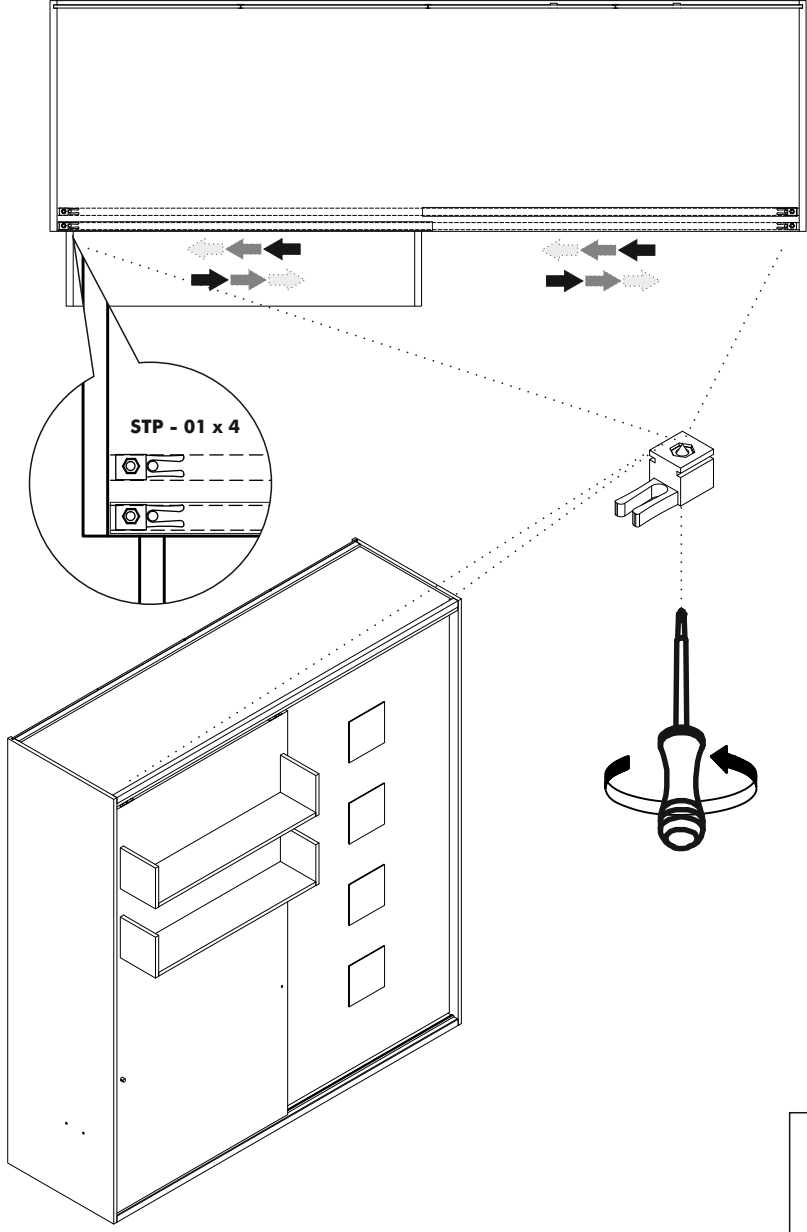

**STEP 23**



MNG - 01



KVL 01



TKR - 01



CT - 07

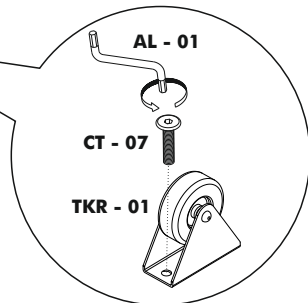
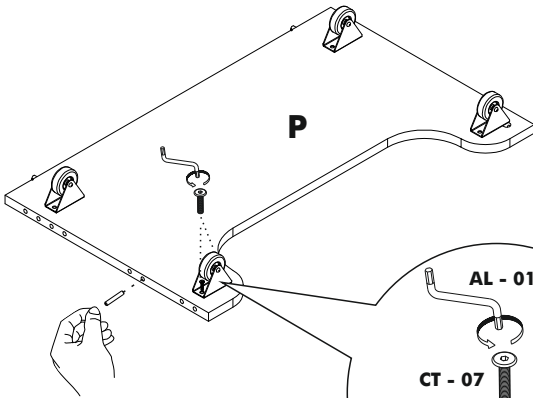
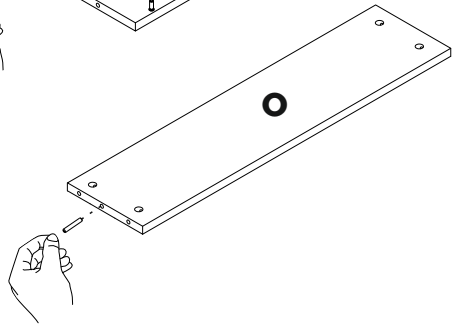
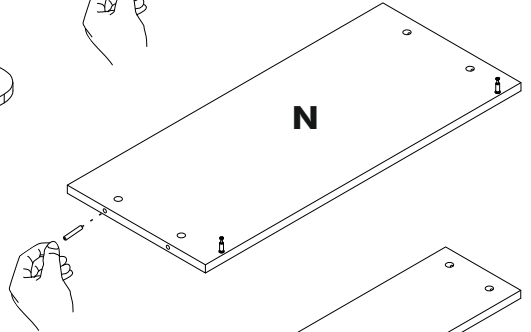
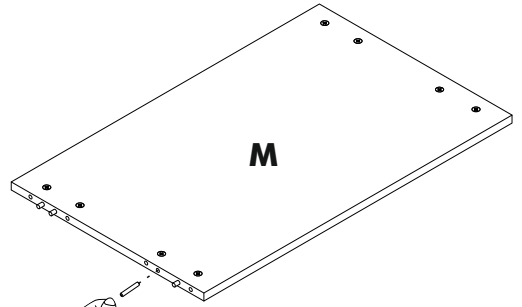
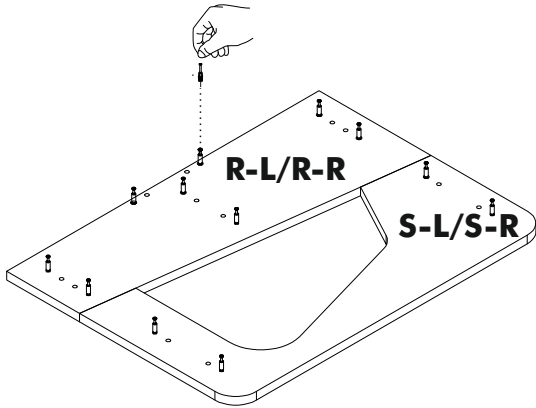

**VIDEO**

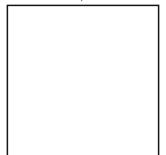

link

**STEP 24**



MNG - 01

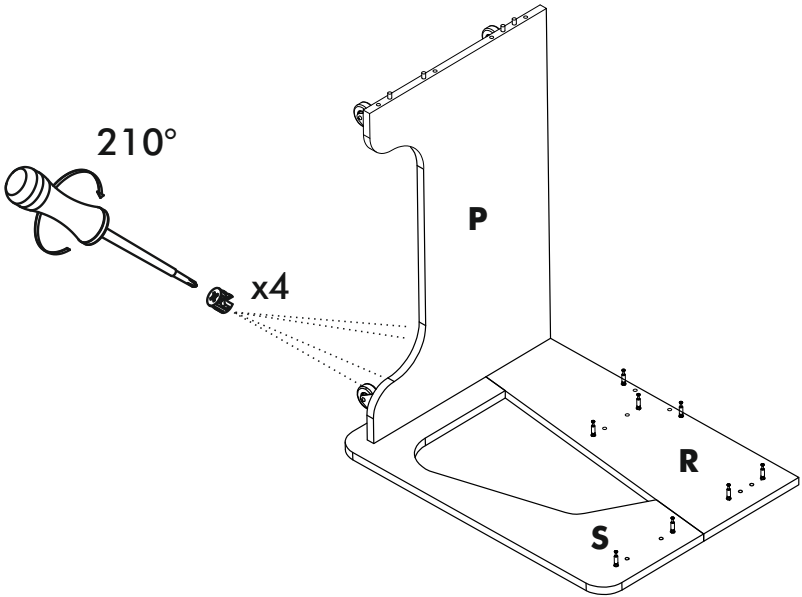

**STEP 25**



MNG - 01

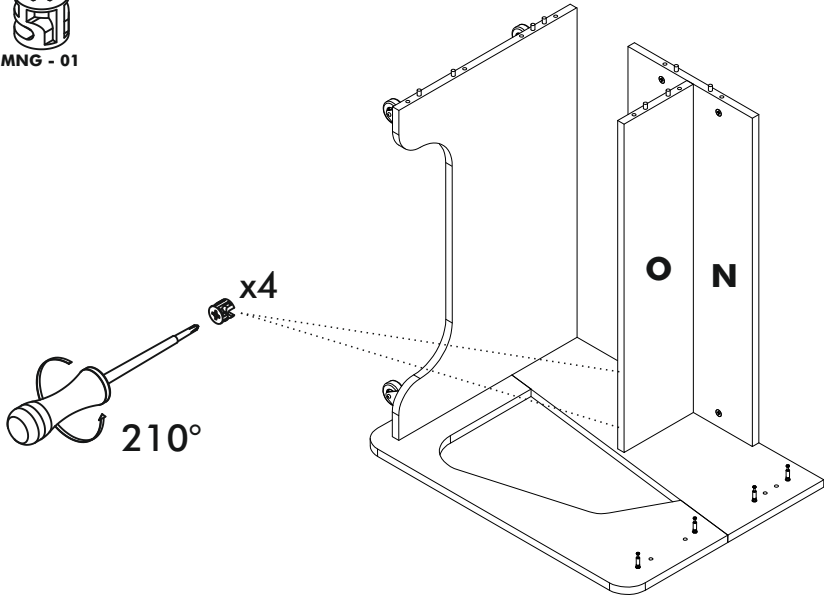

**VIDEO**



link

**STEP 26**



MNG - 01

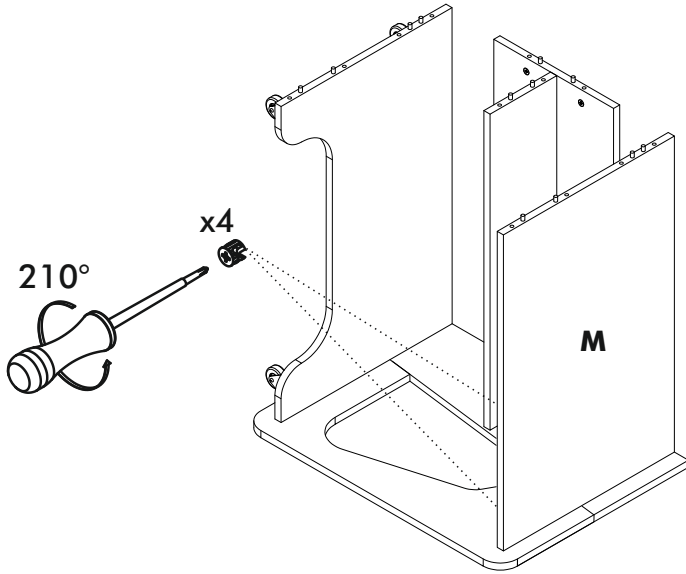

**STEP 27**



MNG - 01

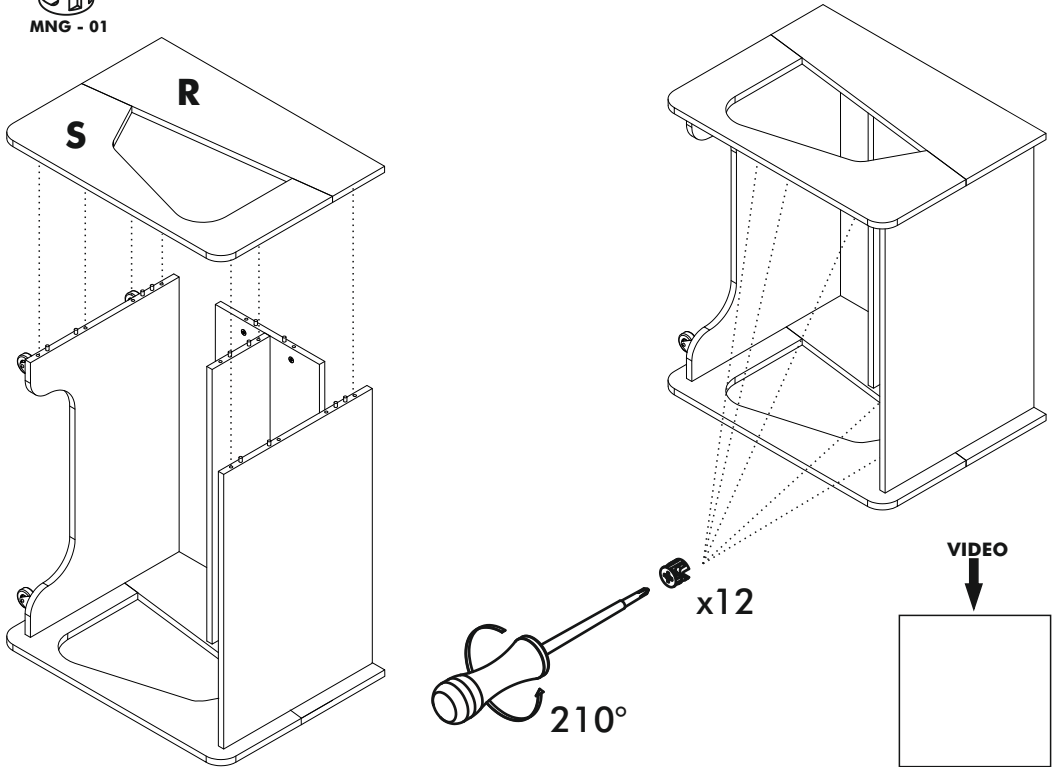

**STEP 28**

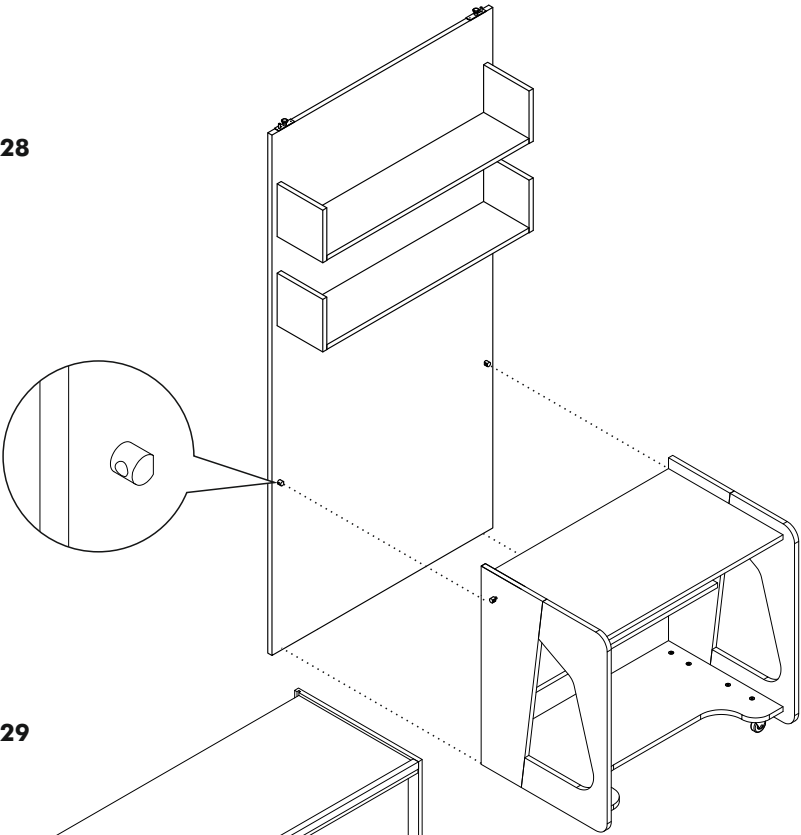

**STEP 29**

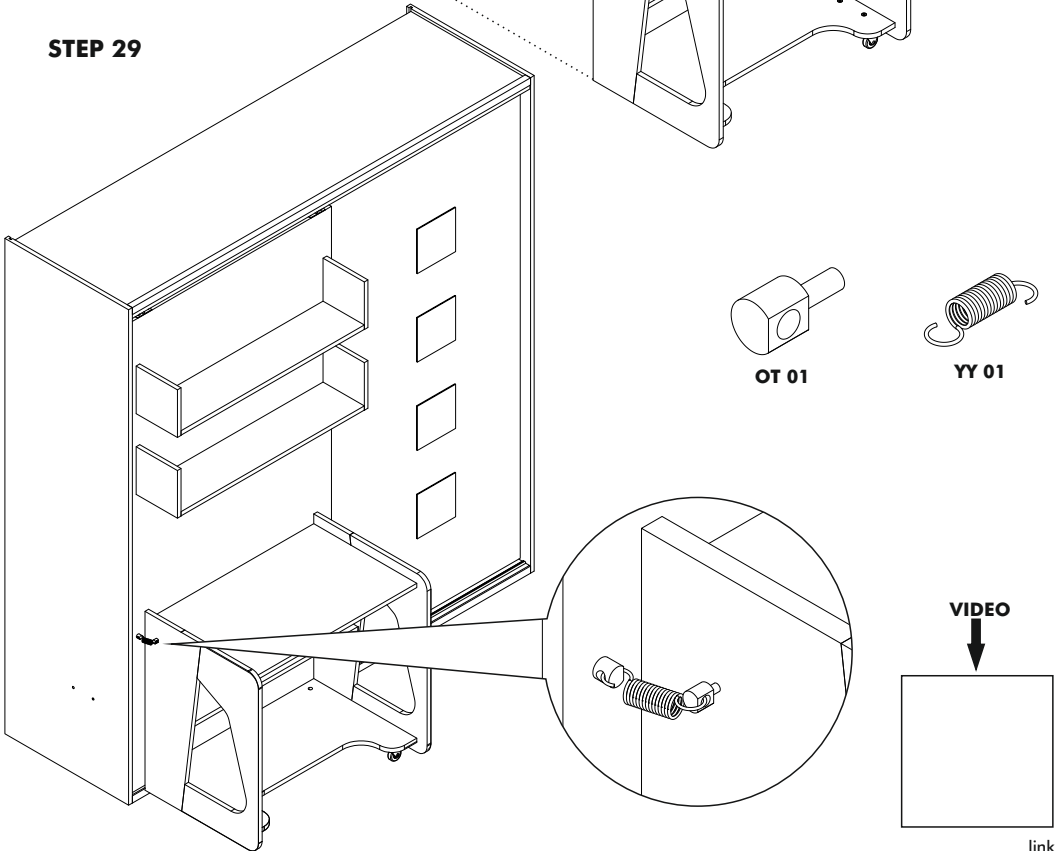

STEP 30

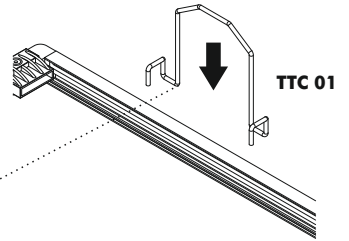
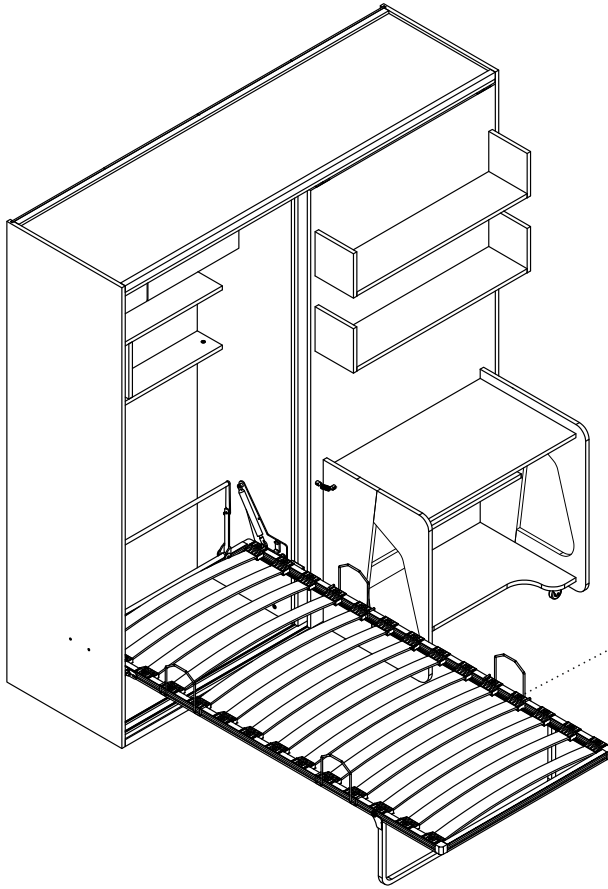

VIDEO

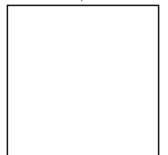

link

## ATTENTION / HOW TO / READ ME / OWNER'S GUIDE

1. When mounting on a regular drywall, furniture must be fastened to wood or metal studs. Solid walls made of brick, concrete or similar strong material are also acceptable. Do not mount furniture to paper-mache or sheet rock like material without properly attaching to stud.

2. For safety and product longevity you must periodically inspect the mounting and mechanical connections for integrity and tightness. Confirm hardware remains properly affixed and connections snug.

3. Wall Bed mattress thickness may not exceed 8 inch. Take care to remove pillows and excess blankets before closing. Doing so keeps mechanism free of obstruction and unnecessary stress.

4. Do not lean or rest heavy objects on side or top of furniture. This may cause balance issues and compromise the integrity of your mounting connections.

5. Please use the furniture's beds, desks and shelving as intended. Not designed to be sat, stood, leaned, jumped (etc) on. Improper use may cause personal injury and damage to property.

6. With seasonal humidity change you must inspect interior and exterior of furniture.

7. Single, Twin, Twin XL beds accommodate the weight of one person. Improperly sleeping more than one person risks injury to person and damage to property.

8. Before any un-mounting or disassembly please contact Multimo for technical support and instruction. Failure to properly detach risks injury to person and damage to property.

### 9. For Bunk Beds:

a. Always use provided ladder when accessing top bunk.

b. Be slow, careful and aware of surroundings when opening top bunk.

c. Do not horseplay. Beds are to be slept on only.

d. Some have legs that fully extend when open- be aware of where the leg is and will be.



**MULTiMO**

[www.multimo.com](http://www.multimo.com)